

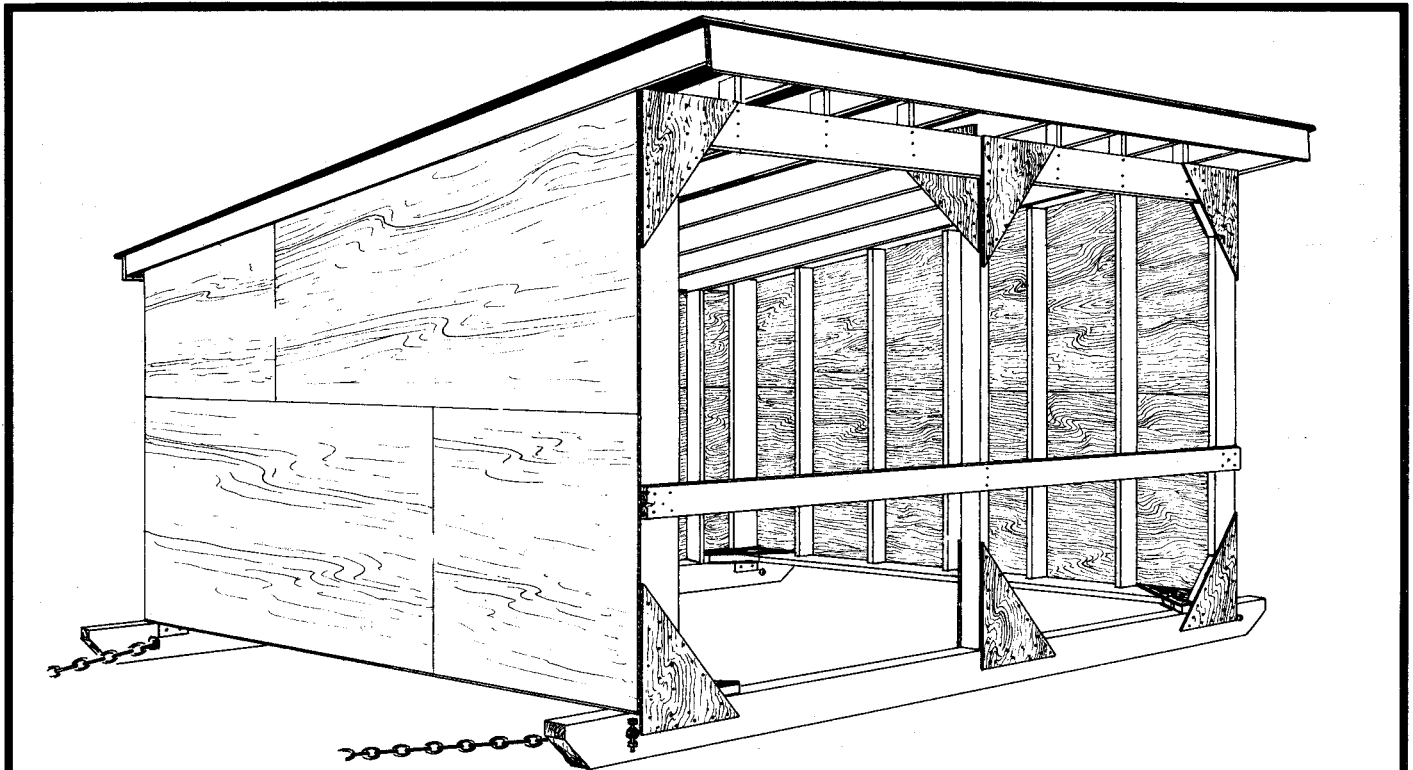

CALF RANGE SHELTER



Portable calf shelters have proven to be very popular with cow-calf ranchers who need additional shelter for young calves on range during chilly wet weather. Page 3 of this leaflet gives details for building such a shelter. Locate it on a well-drained knoll with the open front facing south to benefit from spring sunshine.

This plan is for a shelter 3.6 x 4.8 m, suitable for up to 20 calves. Some ranchers may want to reduce this to a 10-calf shelter 2.4 x 3.6 m so it can be skidded on a flat-bed trailer or truck platform for transportation to remote sites. The height of the roof can also be reduced if the owner doesn't mind stooping.

The shelter is designed to use inexpensive sheathing plywood or Aspenite in 9.5 m thickness for wall and roof covering; buy 18 sheets of 1.2 x 2.4 m sheathing and saw part of these sheets (left over from the back wall and roof panels) into 14

triangular gusset pieces. Frame the shed slightly less than 4.8 m long so that the roof sheathing can overhang the end walls with minimum splicing. Nail all sheathing and gussets to the frame securely with 38 mm large-head galvanized roofing nails so that the building can withstand racking while being moved. Bolt angles for strength under each corner where the skids meet the sill, and nail steel strapping at the center of each endwall sill in case an animal steps onto the sill.

If the site is exposed to strong winds, add a weighted canvas or burlap curtain, and anchor the shed at four corners by wiring it to stakes driven into the ground. Bed the floor liberally with straw, wood chips or other dry bedding material. When the manure pack needs cleaning out, pry the skids carefully out of the manure pack, then tow the shed off the bedded area to a new site. Clean and spread the manure after the shed has been removed.



The Canada Plan Service prepares detailed plans showing how to construct modern farm buildings, livestock housing systems, storages and equipment for Canadian Agriculture.

This leaflet gives the details for a farm building component or piece of farmstead equipment. To obtain another copy of this leaflet, contact your local provincial agricultural engineer or extension advisor.

CALF RANGE SHELTER

PLAN M-1352 NEW 79:4

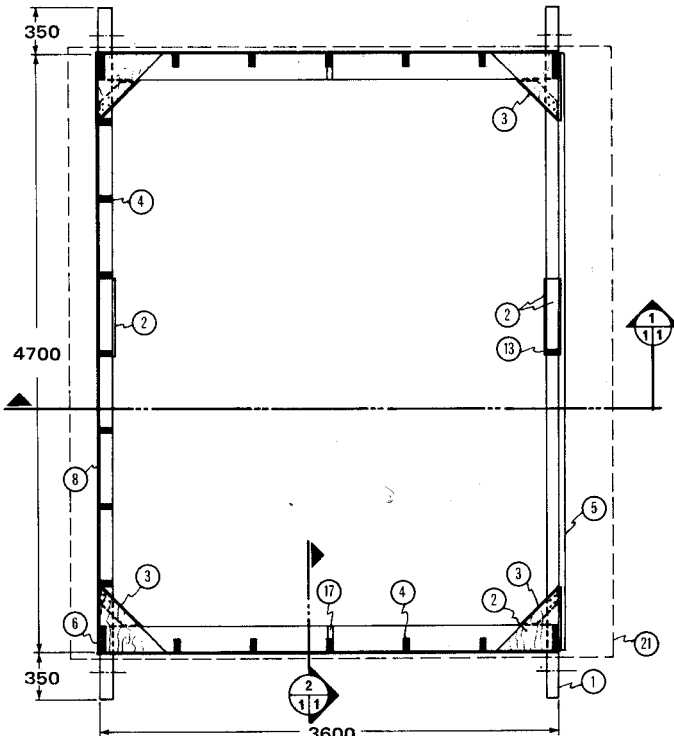

1. 89 x 184 x 5 400 mm skids, 38 mm hole at each end for tow chain,
2. cut plywood or Aspenite gussets diagonally from 9.5 x 600 mm squares, 14 gussets required, 1 1/2" large-head galvanized roofing nails to frames, 38 x 89 mm filler block fitted between gussets
3. 5" spiral nails through gusset and filler block to skid 1
4. 38 x 89 mm studs @600 mm oc,
5. 38 x 140 mm guard, keeps cows outside,
6. 38 x 184 mm corner studs
7. 38 x184 x3600 mm sill
8. 9.5 mm exterior sheathing plywood or Aspenite, rear wall cladding nailed from inside to 9
9. 19 x 89 mm soffit board, 50 mm ventilation slot
10. 19 x 184 mm face board
11. 38 x 140 x 4 200 mm rafters @ 600 mm oc (1.2 kN/m² roof load)
12. 9.5 mm exterior sheathing plywood or Aspenite, caulk all joints and lap 75 mm at horizontal joints, nail with 1 1/2" large-head galv. roofing nails
13. 38 x 89 mm center post, notch for 14
14. 38 x 184 mm beam
15. end rafter spiked from outside thru sheathing
16. endwall cladding stops 6 mm above bottom of sill
17. steel straps nailed tostud and nailed around edge of 7
18. optional canvas wind flap, weighted with 38 x 89 mm stiffener at bottom edge
19. 38 x 89 x 300 mm rafter tie blocks @ 600 mm oc except at end and center rafters (12 required)
20. 1/4" x 3" x 3" x 200 mm lengths steel angle bolted to skids 1 and sill 7 at each corner
21. roof line above

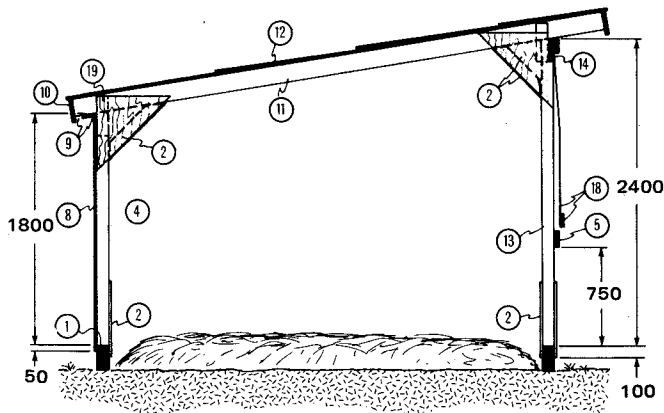

1
11

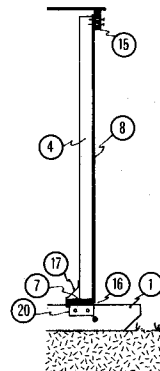

2
11