

N.A. Bird, D.I. Masse

Light restriction is required for poultry housing applications where it is necessary to provide a day length that is shorter than the natural day length, or to provide light and dark periods on an intermittent basis. It can also reduce light intensity near large fans or inlet doors.

This leaflet provides construction details for light restricting fan houses and air intake hoods. The designs of the fan houses are based on the use of commercially available light baffles or vanes. Two examples are "Light Trap", manufactured by the Acme Engineering and Manufacturing Corp. and "Dark Air", manufactured by Sun North Systems Ltd. For air intake hoods the choice of light-restricting methods are either an extended straight hood without vanes, or a short hood with vanes. Light-restricting vanes are required for large window or door inlets. Since light restricting devices also restrict air flow and cause exhaust fans to work against higher static pressures, it is important to have inlet and exhaust opening areas that equal or exceed the minimum size for the air flows required. Select exhaust fans to give the required capacity at 30 Pa (1/8 in. water gauge) static pressure.

FAN HOUSES

Construction details for light-restricting fan houses suitable for single story houses, high rise cage houses and two-story houses are shown in Figures 1, 2 and 3, respectively.

The light vane assembly is installed in the fan house so as not to obstruct the pen area or aisle and to protect the vanes from physical damage. A poultry screen may be needed on the pen side.

A fan house width of 1800 mm (6 ft) is recommended to allow sufficient space for equipment and servicing. On single story buildings, this width will still provide sufficient eave height for the installation of exhaust fans.

The length of the fan house must be determined by first designing the opening size in the pen wall, then adding space for an access door at one end of the opening. Finally, the length must be checked to be sure there is sufficient wall space to install the exhaust fans selected. For example, consider the design of fan houses for a 30 000 bird caged pullet house. The cage room is 11 x 72 m (36 x 240 ft). Assume the

COMPLETE INSTRUCTIONS

The Canada Plan Service, a Canadian federal/provincial organization, promotes the transfer of technology through factsheets, design aids and construction drawings that show how to plan and build modern farm structures and equipment for Canadian agriculture.

For more information, contact your local provincial agricultural engineer or extension advisor.

WARNING This leaflet gives structural choices you must select to meet local climatic loads (wind, snow), soil-bearing capacity and other local conditions. You must ensure that these requirements are met. Consult an engineer if you are not familiar with the details required.

FIGURE 1. LIGHT-RESTRICTING FAN HOUSE FOR A SINGLE STORY BARN

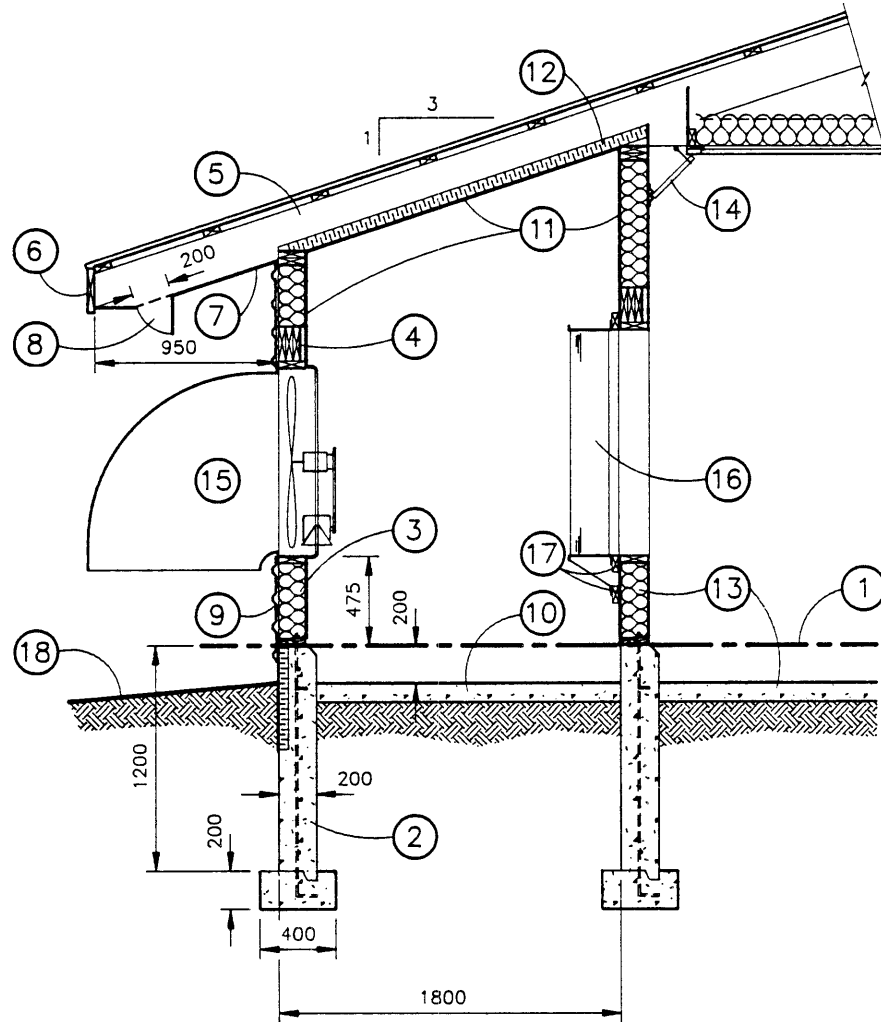

- | | |
|--|---|
| <p>1 datum line, top of concrete foundation</p> <p>2 insulated concrete foundation, see Plan M-9324 for details</p> <p>3 38 x 140 mm (2 x 6 in.) studs @ 600 mm (2 ft 0 in.) o.c.</p> <p>4 lintel, for size see Leaflet M-9312</p> <p>5 steel roofing; 38 x 89 mm (2 x 4 in.) purlins @ 600 mm (2 ft 0 in.) o.c.; 38 x 235 mm (2 x 10 in.) upper chord extensions @ 1200 mm (4 ft 0 in.) o.c.</p> <p>6 38 x 235 mm (2 x 10 in.) face board</p> <p>7 9.5 mm (3/8 in.) plywood sheathing soffit</p> <p>8 hinged vent c/w screened opening</p> <p>9 horizontal or vertical prefinished metal Siding</p> | <p>10 100 mm (4 in.) concrete floor on 150 mm (6 in.) compacted gravel fill</p> <p>11 9.5 mm (3/8 in.) plywood sheathing, walls & ceiling</p> <p>12 62 mm (1 1/2 in.) rigid insulation</p> <p>13 wail and floor construction as shown in Plan 5101</p> <p>14 slot air inlet, use commercially available cable controlled unit or see Leaflet M-9714</p> <p>15 typical fan installation</p> <p>16 light trap, Acme or equal; 1200 mm (4 ft 0 in.) high</p> <p>17 38 x 89 mm (2 x 4 in.) strapping to support 16</p> <p>18 finished grade</p> |
|--|---|

FIGURE 2. LIGHT-RESTRICTING FAN HOUSE FOR A HIGH RISE LAYER BARN

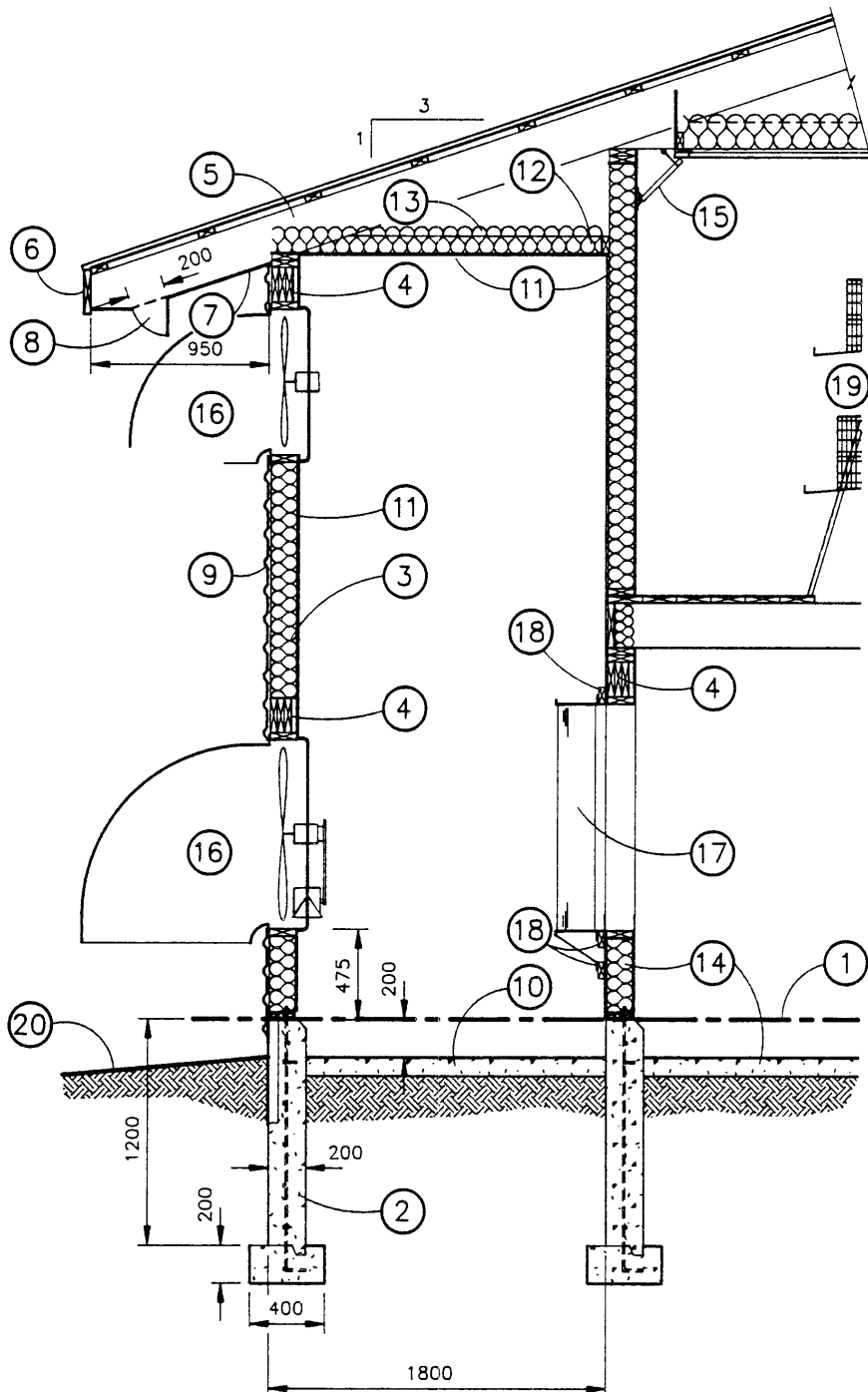

- | | |
|--|---|
| <p>1 datum line, top of concrete foundation
 2 insulated concrete foundation, see Plan M-9324 for details
 3 38 x 140 mm (2 x 6 in.) studs @ 600 mm (2 ft 0 in.) o.c.
 4 lintel, for size see Leaflet M-9312
 5 steel roofing; 38 x 89 mm (2 x 4 in.) purlins @ 600 mm (2 ft 0 in.) o.c.; 38 x 235 mm (2 x 10 in.) upper chord extensions @ 1200 mm slot air inlet, use commercially available cable controlled unit or see (4 ft 0 in.) O.C.
 6 38 x 235 mm (2 x 10 in.) face board
 7 7.5 mm (3/8 in.) plywood sheathing soffit
 8 hinged vent c/w screened opening
 9 horizontal or vertical prefinished metal siding</p> | <p>10 100 mm (4 in.) concrete floor on compacted gravel fill
 11 9.5 mm (3/8 in.) plywood sheathing, walls & ceiling
 12 38 x 89 mm (2 x 4 in.) blocking @ 600 mm (2 ft 0 in.) o.c.
 13 RSI-2. t (Rt 2) ball insulation
 14 floor and wall construction as detailed in Plan 5211
 15 slot air inlet, use commercially available cable controlled unit or see Leaflet M-9714
 16 typical fan installation
 17 light trap, Acme or equal; 1200 mm (4 ft 0 in.) high
 18 38 x 89 mm (2 x 4 in.) strapping to support 17
 19 tiered laying cages
 20 finished grade</p> |
|--|---|

FIGURE 3. LIGHT-RESTRICTING FAN HOUSE FOR A TWO-STORY BARN

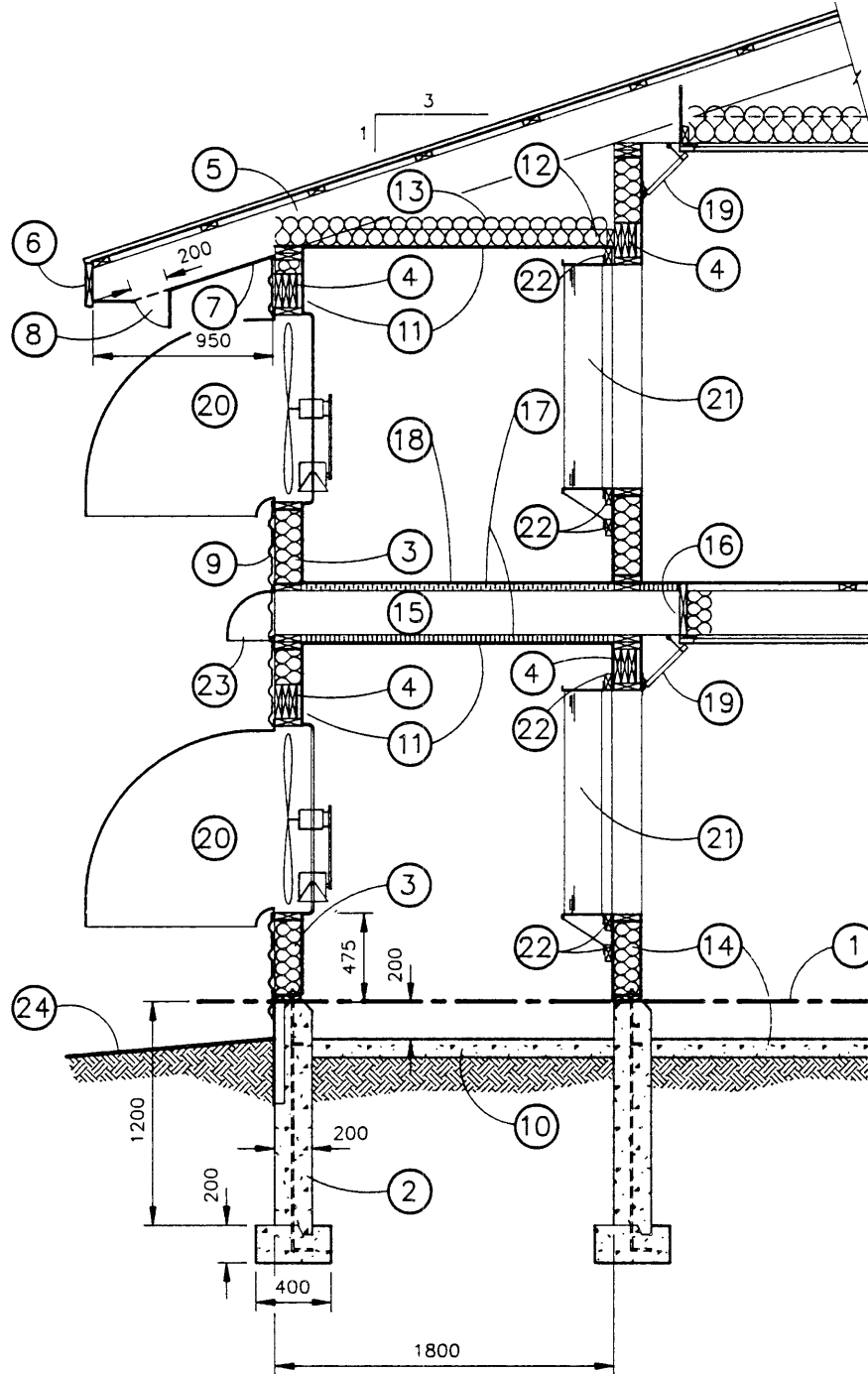

- | | |
|--|--|
| <p>1 datum line, top of concrete foundation
 2 insulated concrete foundation, see Plan M-9324 for details
 3 38 x 140 mm (2 x 6 in) studs @ 600 mm (2 ft 0 in.) oc
 4 lintel, for size see Leaflet M-9312
 5 steel roofing; 38 x 89 mm (2 x 10 in) upper chord extensions @ 1200mm (4 ft 0 in.) oc
 6 38 x 235 mm (2 x 10 in) face board
 7 9.5 mm (3/8 in) plywood sheathing soffit
 8 hinged vent c/w screened opening
 9 horizontal or vertical prefinished metal siding
 10 100 mm (4 in) concrete floor on 150 mm (6 in) compact gravel fill
 11 9.5 mm (3/8 in.) plywood sheathing, walls & ceiling
 12 38 x 89 mm (2 x 4 in.) blocking @ 600 mm (2 ft 0 in.) oc</p> | <p>13 RS-2.1 (R12) batt insulation
 14 floor and wall construction as shown in Plan 5318
 15 joist extension, omit header for air intake
 16 38 mm (1 1/2 in.) blocking between joists
 17 38 mm (1 1/2 in.) rigid insulation above and below floor, to prevent condensation
 18 15.5 mm (5/8 in.) plywood floor
 19 slot air inlet, use commercially available cable controlled unit or see Leaflet M-9714
 20 typical fan installation
 21 light trap, Acme or equal; 1200 mm (4 ft 0 in.) high
 22 38 x 89 mm (2 x 4 in.) strapping to support 21
 23 vent hood, screened air intake
 24 finished grade</p> |
|--|--|

number of fan houses is two. Then use Leaflet: M-9700 to select the minimum (step 1) ventilation rate and the maximum summer ventilation rate per fan house. The step 1 rate will be 300-2100 L/s (600-4200 cfm) and the maximum summer rate will be 36 000 L/s (75 000 cfm).

Next, size the opening. Using the recommendations of the light vane manufacturer, select an acceptable air speed and then calculate the required opening area. Acme, for example, recommends a maximum air speed of 3.8 m/s (750 ft per min) for their "Light Trap" when used for exhaust fans. Using this light trap, the required minimum opening area can be calculated by dividing the air flow in m³/s by the maximum air speed in m/s to give 9.47 m². In imperial units, divide the air flow in cfm by the maximum air speed in ft per min to give 100 sq ft.

Select a 1500 x 6300 mm (5 x 21 ft) opening. An 8400 mm (28 ft) long fan house could accommodate this size of opening and also space for an access door from the pen to the fan house. Be sure to select an opening height that corresponds to available lengths of vanes.

As these openings will always exceed 600 mm (2 ft) a lintel is required above the opening. An opening such as 6300 mm (21 ft) could be broken into two or more openings of shorter length with double or triple studs as dividers. The size of the lintel will depend on the length of these openings as well as the roof snow load at your site. Leaflet M-9312, Plate Beams and Lintels, can be used to determine the size of lintel required. For more information on lintel selection, check with your local provincial engineer or extension advisor.

Using Leaflet M9705 and the certified fan performance ratings from fan manufacturers, select the fans for each fan house. Remember to select on the basis of 30 Pa (1/8 in. water gauge) static pressure. This is important because of the added resistance of the vanes on both the intake and exhaust openings. Assume, for example, that one Danor SD12-EVX, one Danor SD18-FVX and five Danor SB42J fans are selected. Allowing 1200 mm (4 ft) of wall space per fan, a wall length of 8400 mm (28 ft) will be adequate to accommodate the selected fans.

To maintain the continuity of the air inlet above the fan house, air is delivered from the eave through the fan house rafter space to the air inlet baffle board. For a two-story building with inlet baffle boards on the fan side, air is also delivered through the fan house in the joist space to the first floor baffle board. The joist space must be insulated on top and below to prevent condensation. Since most two-story barns are used for floor pen rearing, adequate air distribution may be possible without installing an inlet on the fan side of barn, thus eliminating the need for the air inlets through and over the two-storey fan house.

LIGHT-RESTRICTING AIR INTAKE HOODS

Plans for light-restricting air intake hoods without vanes are shown in Figures 4 and 5. These intake hoods have capacity for 600 L/s per metre of length (400 cfm per ft of length). This is adequate for two cage rows of pullets or layers, or 215 pullets

or layers per metre of inlet (66 per ft). Cage rows higher than five decks or cage housing wider than four rows will require a larger air intake hood.

Plans for air intake hoods with vanes are shown in Figures 6 and 7. If vanes are spaced 30 mm apart (minimum overlap), then 10 vanes are required for the inlet shown in Figures 6, and 7 vanes for the inlet shown in Figure 7. The inlet in Figure 6 has a capacity of 720 (L/s)/m (470 cfm/ft) while the inlet in Figure 7 has a capacity of 500 (L/s)/m (320 cfm/ft). Vanes can be spaced wider apart than normally recommended in order to reduce cost and air resistance; however, the light-restricting effectiveness will also be reduced. This choice will depend on the degree of light restriction required.

If window or door type inlets or motorized shutter inlets are used, install a vane assembly over the opening. A typical installation is illustrated in Figure 8. Follow the recommendations of the vane manufacturer in sizing such openings and vane assemblies. Do not exceed an air speed of 2.5 m/s (500 ft per min) for vane assemblies. This requires an inlet opening area of 0.4 m² per 1000 L/s (2 sq ft per 1000 cfm).

There may be some solar heat gain from the air intake hoods depending on orientation. Use white painted metal cladding for hoods if they will be exposed to the sun.

EXISTING FANS

Light restriction for existing fans can be achieved as follows: construct a short rectangular duct leading to the fan and install a vane assembly. Design the duct and assembly for an air speed of 3.8 m/s (750 ft per min) or less. The clear distance between the vanes and the fan should be at least equal one-half the fan diameter.

NATURAL VENTILATION

Light restriction for naturally ventilated housing requires that a complete fan-powered ventilation system including both fan houses and light-controlled inlets also be installed. These are needed since the natural ventilation sidewall doors must close during the darkout period.

FIGURE 4 LIGHT-RESTRICTING AIR INTAKE HOOD AT EAVE

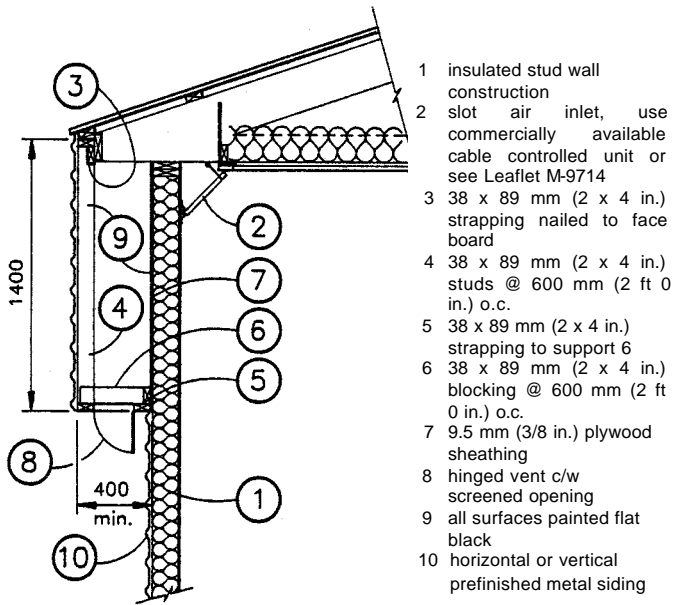

FIGURE 6 LIGHT-RESTRICTING AIR INTAKE HOOD WITH VANES (OVER-THE-PLATE)

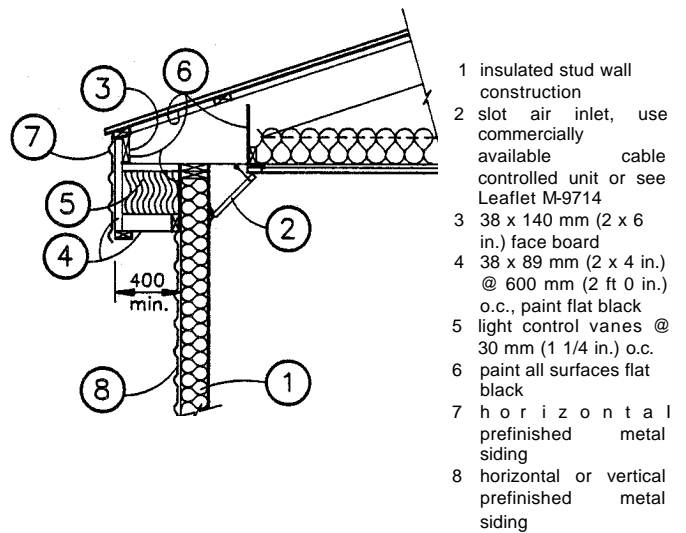

FIGURE 5 LIGHT-RESTRICTING AIR INTAKE HOOD AT WALL MIDHEIGHT

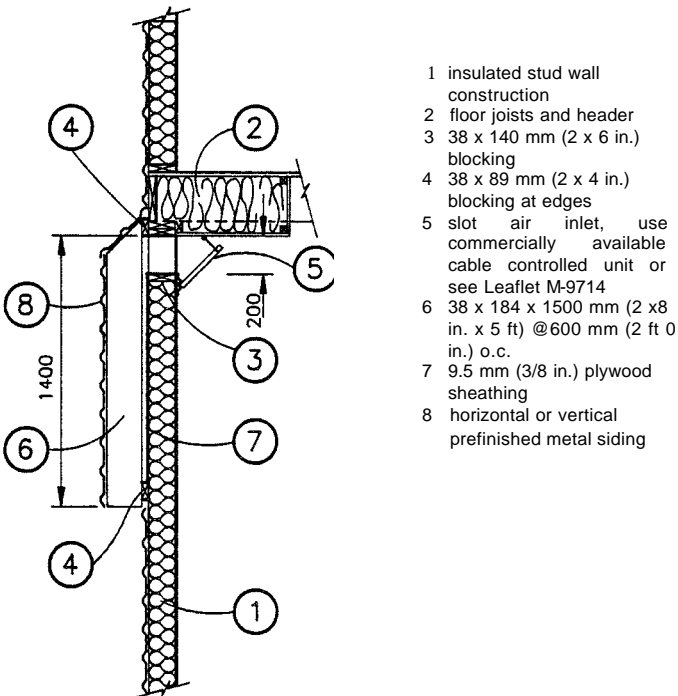
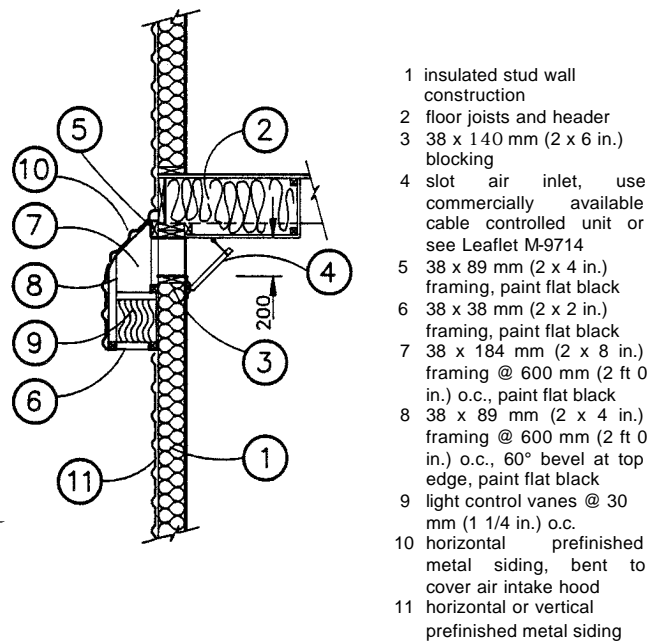

FIGURE 7 LIGHT-RESTRICTING AIR INTAKE HOOD WITH VANES (THROUGH-THE-WALL)



It may be possible to use ridge openings both for exhaust during natural ventilation and intake during fan ventilation. A vane assembly can be installed in each ridge opening, or in the case of a continuous; open ridge, a vane assembly can be installed above the ridge. You will have to provide a roof over the assembly. The vanes should be installed at the normal spacing recommended with exhaust fans; since they will be subject to dirty exhaust air. As an alternative to using the ridge as part or all of the air inlet, some or all of the inlet opening can be placed in

the end walls with power shutters or automatic curtain closures.

ACKNOWLEDGEMENTS

The comments and suggestions from J. Munroe, and the Canada Plan Service Poultry Committee members B. English, W. Winchell, G. Bishop and D. Hodgkinson, and the artwork of R. Pella are greatly appreciated.

FIGURE 8. LIGHT-RESTRICTING VANES INSTALLED OVER A WINDOW OPENING

