

TRUSS ERECTING AND BRACING

COMPLETE INSTRUCTIONS

REV. 86:04

A truss rafter roof system, properly designed, fabricated, erected and braced, is a strong and economical way to frame a farm building roof. However, if the design assumptions are ignored during erection and bracing, the structure may collapse. Individual trusses may fail if damaged during transport or erection. The following points outline procedures and precautions recommended to ensure safe truss erection:

- Trusses have very little strength in the lateral direction; when hoisting and handling, take extreme care to avoid damaging trusses or overstressing the wooden members and the connections (Figure 1). Do not allow the trucker to drive out from under the load of stacked trusses.
- Plan and mark out the locations of the roof purlins while the trusses are stacked on the ground.
- Erect trusses up to 9 m (30 ft) span by lifting them upside down onto the wall plates. Then tip the trusses into the upright position (Figure 2). Temporary truss and wall bracing will be required until the trusses are all secured.
- With larger trusses, spanning from 9-12 m (30-40 ft), use a forklift, front-end loader or crane to lift the trusses in the upright position onto the top plate. Lift trusses from at least two pickup points. Attach a rope to the truss to guide it into position from ground level (Figure 3).
- With trusses spanning 13.2 m (44 ft) and more, use a strongback; it may be any stiff material such as pipe, steel beam or heavy timber. Clamp or tie the strongback to each truss at points not over 2.4 m (8 ft) apart, and above the mid-height of the trusses to prevent overturning (Figure 4).
- Position the first truss at one end of the building and brace it to the ground. These temporary braces must support the trusses against wind from either direction (Figure 2).

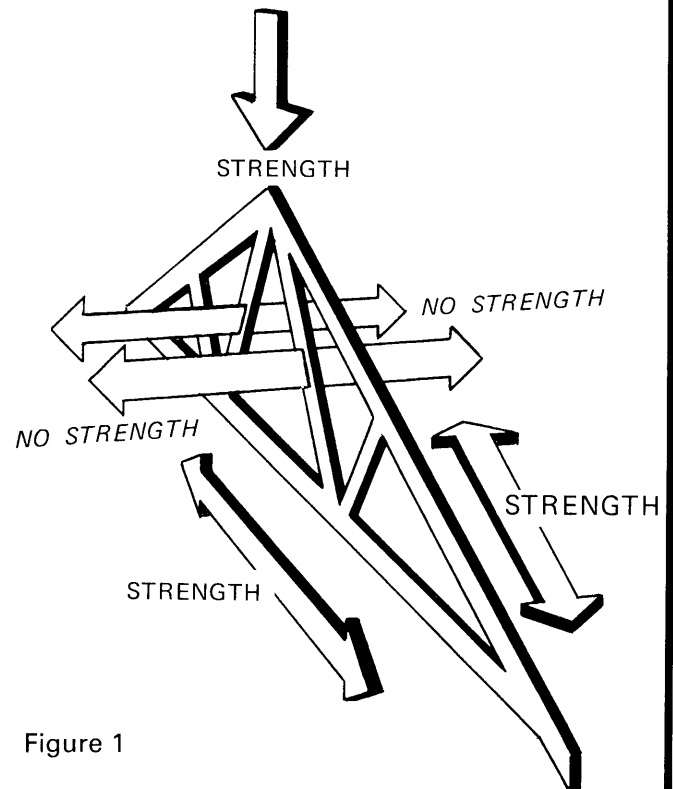

Figure 1

- Position the second truss, spacing it from the first one with short 2.4 m (8 ft) purlins (Figures 2). These first purlins will later alternate with 4.8 m (16 ft) purlins to stagger the end joints. These first purlins are very important because they provide lateral support to the top chords which are susceptible to lateral buckling if not properly braced, even if the trusses are only supporting their own weight.
- Set the third truss into position and fasten it to the first two with the first short purlins. Then set the

TRUSS ERECTING AND BRACING

fourth truss into position and fasten it to the previous trusses with long 4.8 m (16 ft) purlins alternating between the short ones. Fasten all subsequent trusses with long purlins. This sequence is illustrated in Figure 5. As soon as four or five trusses are erected and braced with purlins, install some roof sheathing. If you can't do this yet, add temporary cross-bracing on top of the purlins (Figure 5) at the end of the building to prevent buckling of all top chords together.

- The truss design engineer is responsible to check for possible buckling of compression web members; his engineering drawings specify wherever stiffeners are required for lateral support. There is still a possibility that all webs could buckle in the same direction, so permanent cross-braces should be added to the longitudinal stiffeners at each end of the building (Figure 6). Similar permanent longitudinal stiffeners and cross-bracing are required for tension web members 2.4 m (8 ft) and longer in case of stress reversal (wind uplift, etc.).

It is also recommended that permanent cross-bracing be installed at midspan between truss pairs at both ends of the building (Figure 6,). In longer buildings, this permanent cross-bracing should be repeated at approximately 30 m (100 ft) intervals as well.

- If there is no ceiling, install permanent continuous longitudinal stiffeners to top or bottom of truss

lower chords, preferably where webs join, but not over 2.4 m (8 ft) on center (Figure 6). The crossbracing shown provides support for both the web and lower chord longitudinal stiffeners. Special bracing of the long compression web of a single-slope truss is shown in Figure 7.

- As each truss is positioned, attach both ends permanently to the top of the wall using metal straps, framing anchors, or bolts (Figure 8). Toenailing the truss to the plate is inadequate. Wind can lift off the entire roof if not properly anchored.
- Do not use the trusses as a working platform until they are permanently braced. Never overload trusses by applying concentrated loads such as a pile of roof sheathing, shingles, etc. in one spot.
- Never leave the building site without all temporary and permanent bracing properly installed.
- If the designer specifies wail-to-roof knee braces for wind bracing in the plane of the truss, fasten these to the top chord where the web member joins (Figure 9). This eliminates bending stresses in the top chord that would develop if the knee braces were fastened between web members. The knee brace is fastened to the bottom chord for lateral support only. Also note that with wind, knee bracing tends to lever the truss up and away from the leeward wall. Therefore knee bracing calls for extra care at the truss-to-wall connections.

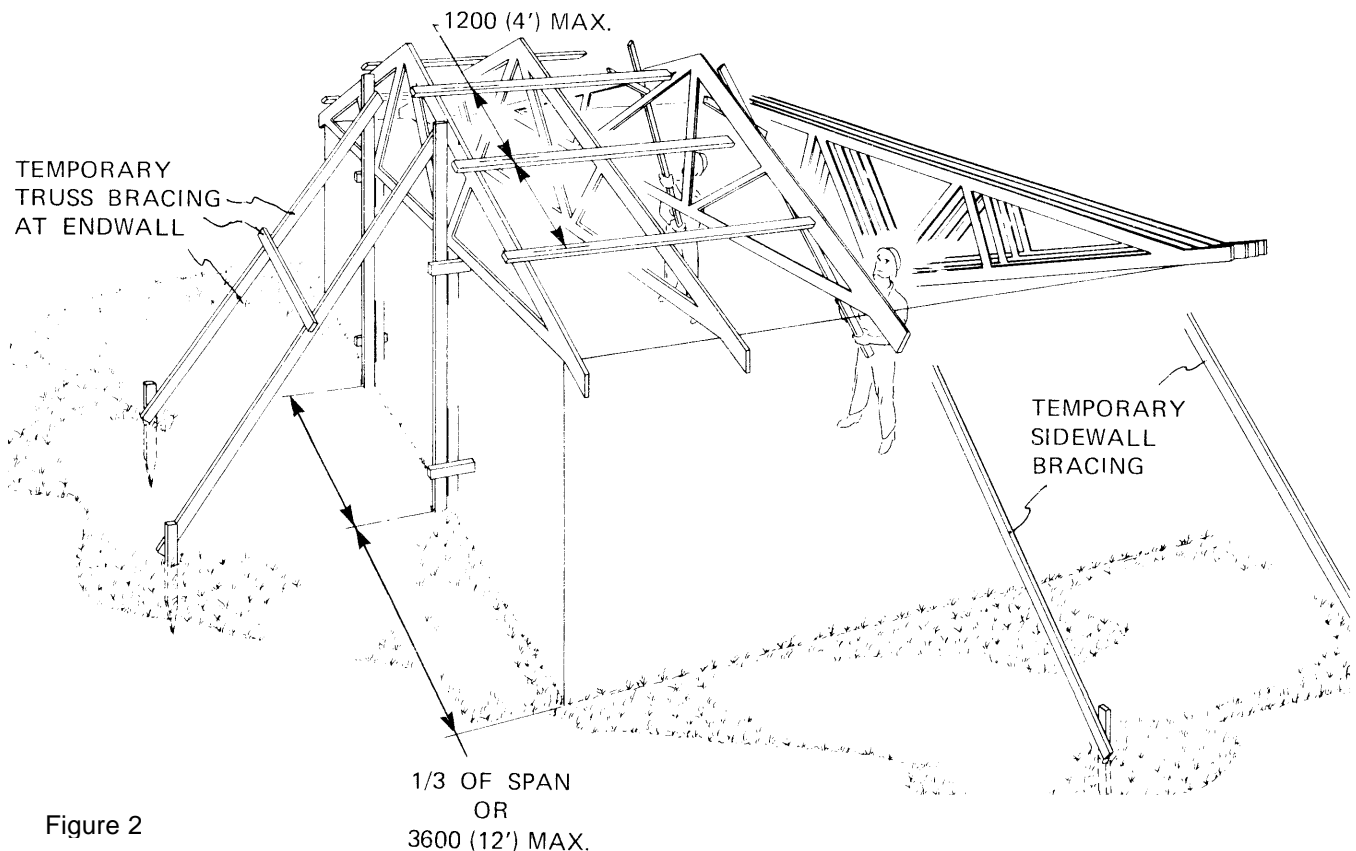
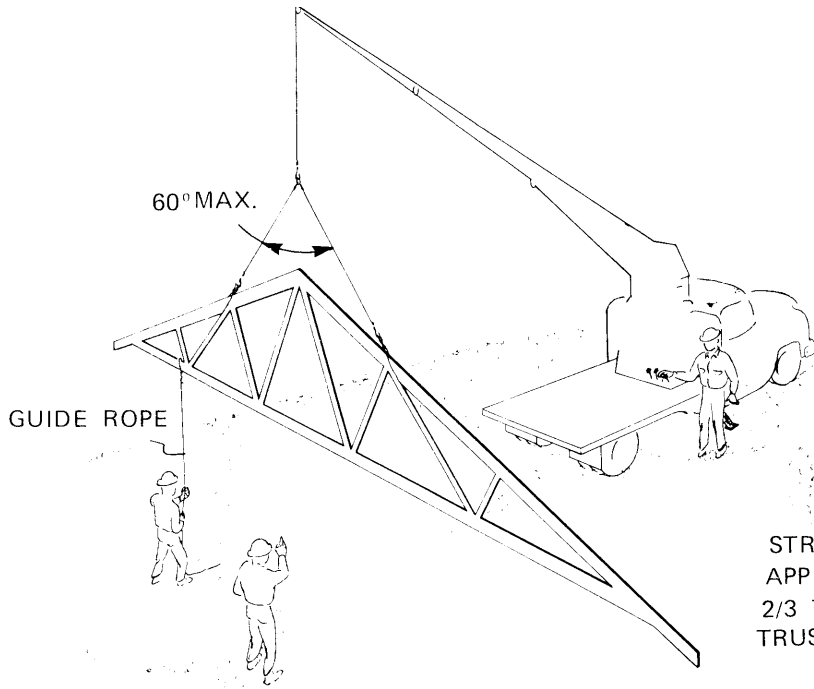

Figure 2



GUIDE ROPE

60° MAX.

TRUSSES 9000 (30') - 13200 (44')

Figure 3

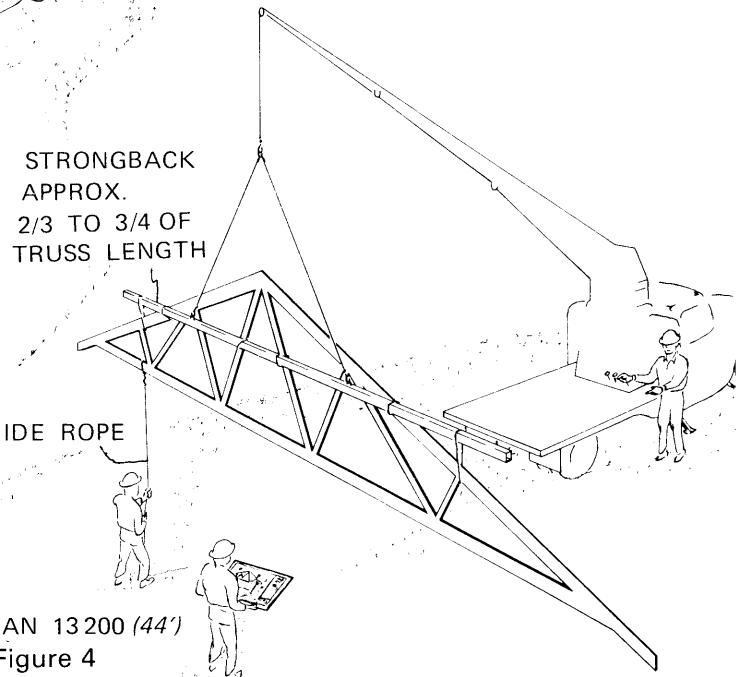

STRONGBACK
APPROX.
2/3 TO 3/4 OF
TRUSS LENGTH

GUIDE ROPE

TRUSSES LONGER THAN 13200 (44')

Figure 4

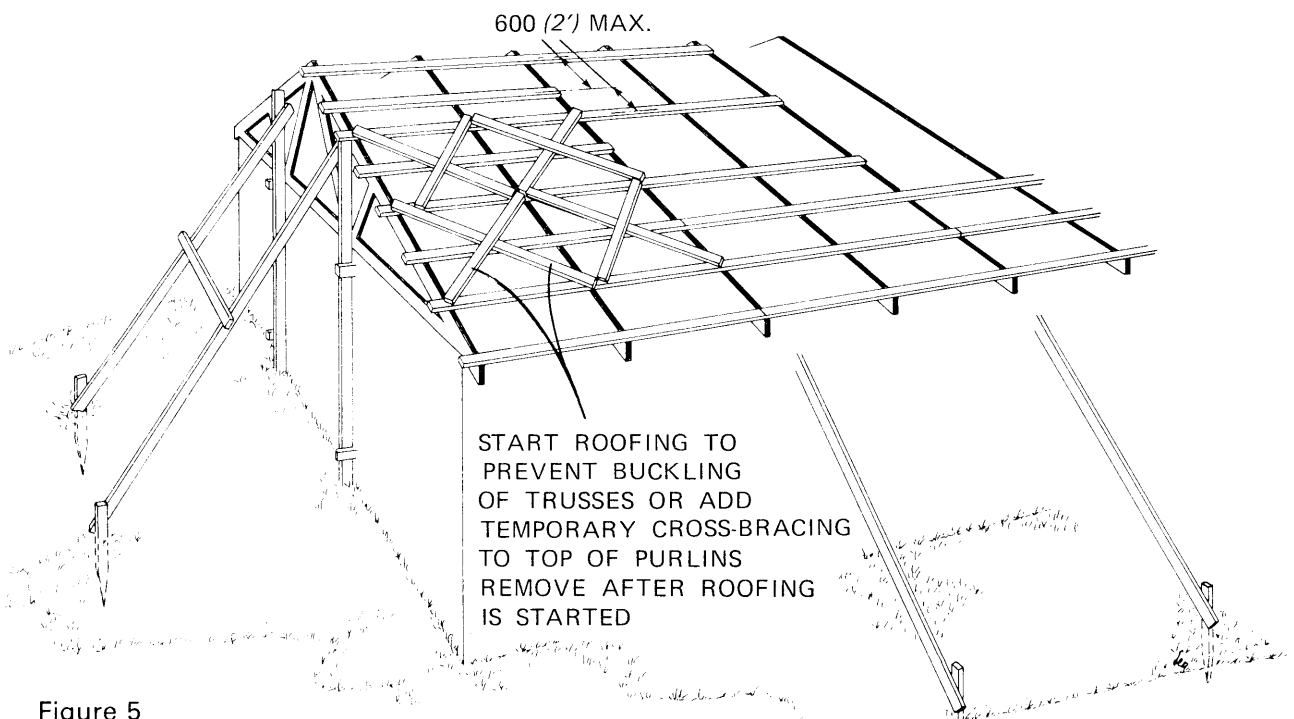

600 (2') MAX.

START ROOFING TO
PREVENT BUCKLING
OF TRUSSES OR ADD
TEMPORARY CROSS-BRACING
TO TOP OF PURLINS
REMOVE AFTER ROOFING
IS STARTED

Figure 5

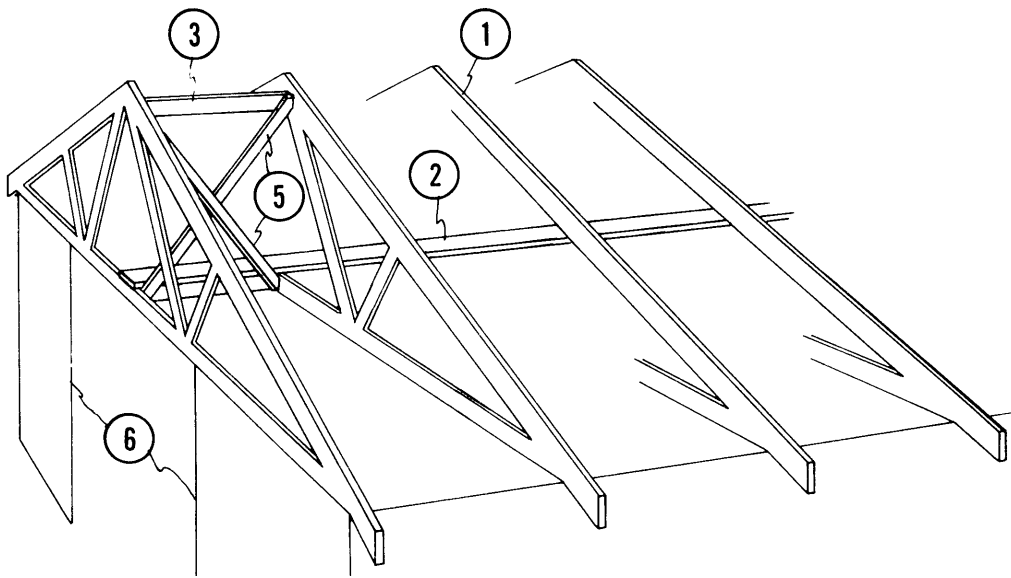

- 1 trusses at 1200 mm (4 ft) oc
- 2 truss lower chord stiffener or walk plank (up to 2400 mm oc, if no ceiling)
- 3 38x140 mm (2x6) blocking between end trusses (see 6)
- 4 longitudinal stiffeners for compression web members, see truss plan
- 5 cross-bracing, 38 x 140 mm (2 x 6) typical not over 3600 mm (12 ft) oc across endwall
- 6 cross-bracing should be at corners and center of wide endwall doorways to stiffen door track and header (see M-9341, Sliding Doors)

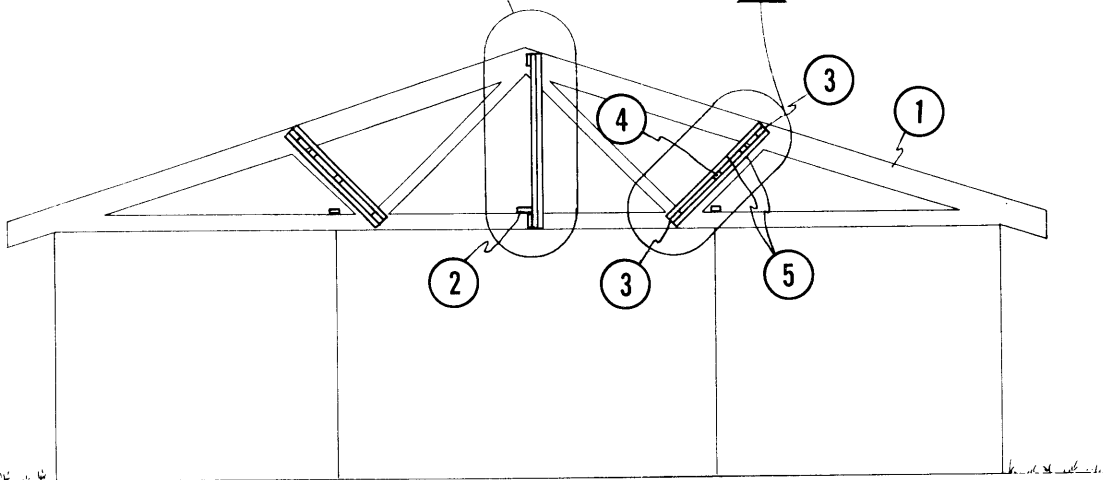
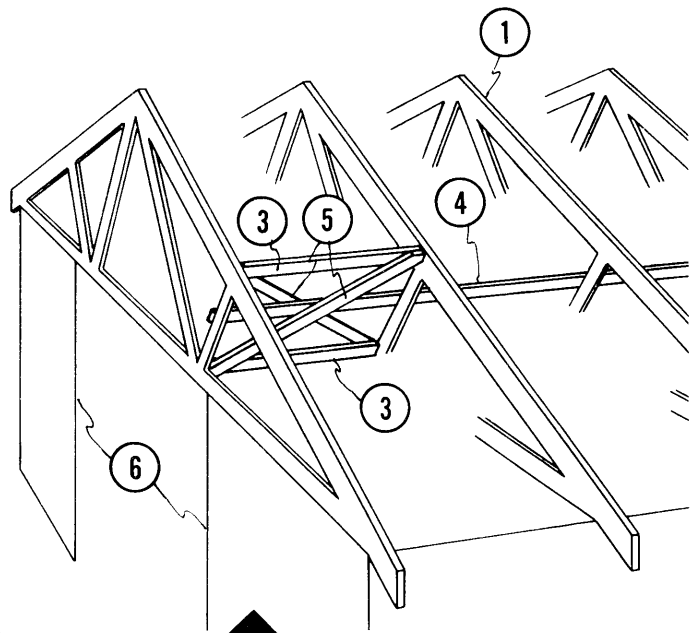

Figure 6

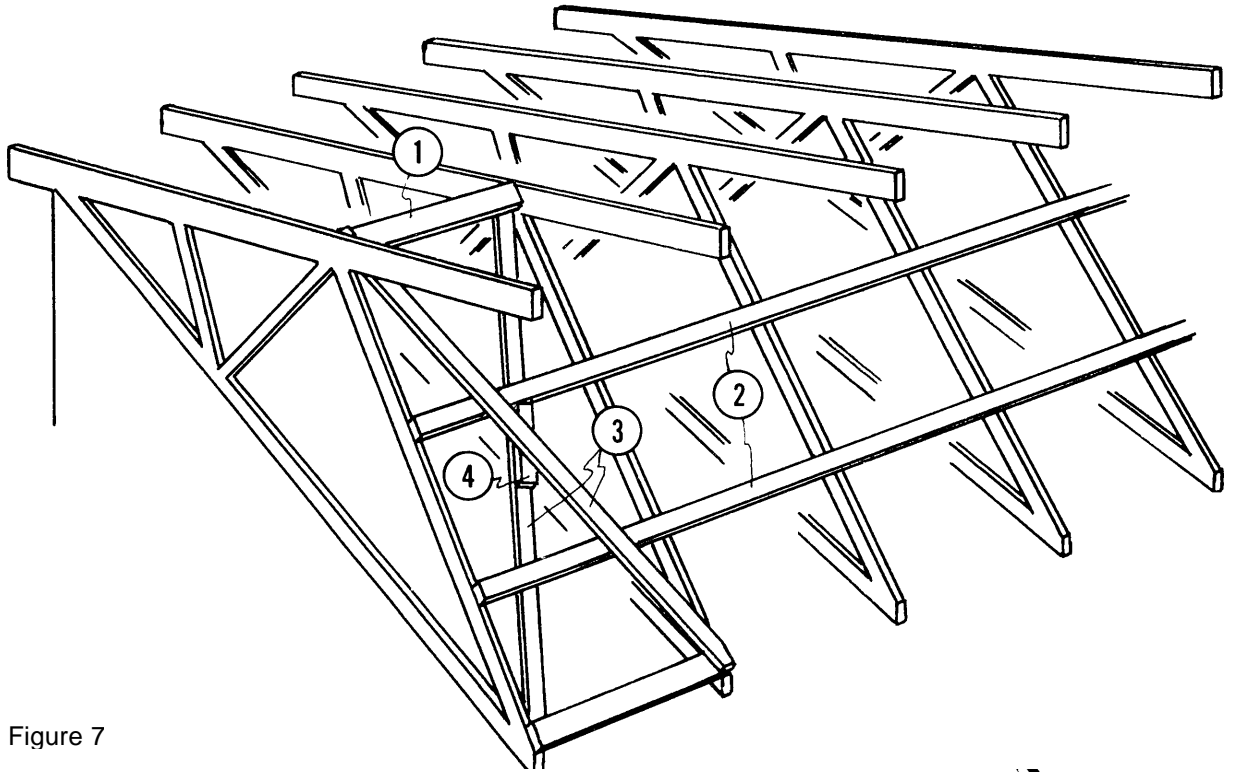

Figure 7

- 1 38 x 140 mm (2 x 6) blocking between end pair of trusses
- 2 38 x 64 mm (2 x 3) longitudinal stiffener for compression web members (see truss plan)
- 3 38 x 140 mm (2 x 6) cross-bracing above and below 2
- 4 38 x 140 mm (2 x 6) block between 3

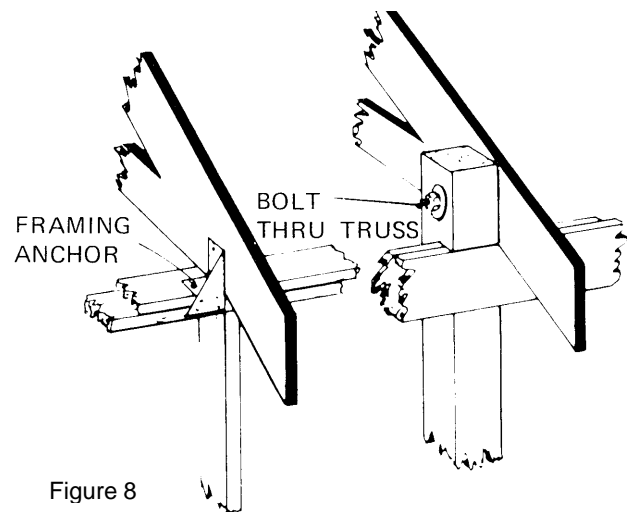

Figure 8

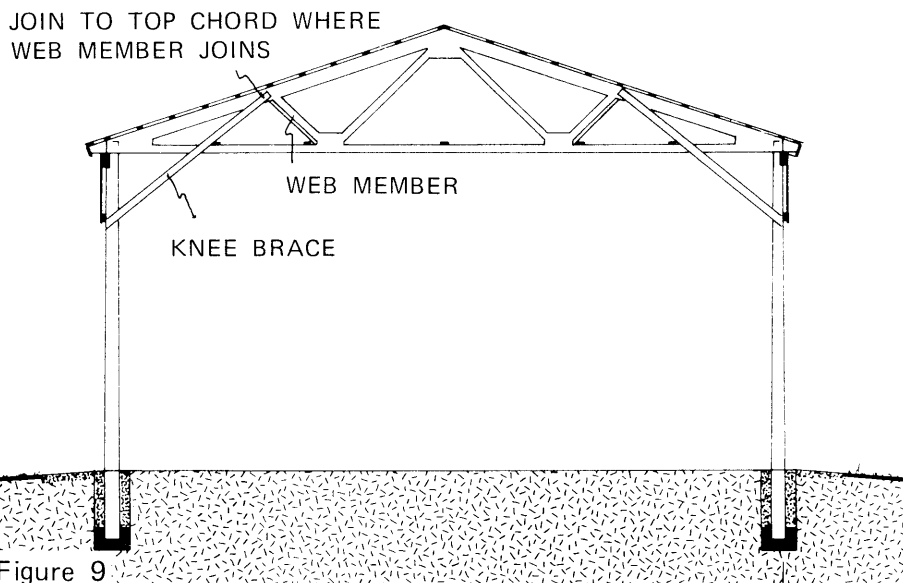

Figure 9