

COMPLETE INSTRUCTIONS

The Canada Plan Service, a Canadian federal/provincial organization, promotes the transfer of technology through factsheets, design aids and construction drawings that show how to plan and build modern farm structures and equipment for Canadian agriculture.

For more information, contact your local provincial agricultural engineer or extension advisor.

WARNING This leaflet gives structural choices you must select to meet local climatic loads (wind, snow), soil-bearing capacity and other local conditions. You must ensure that these requirements are met. Consult an engineer if you are not familiar with the details required.

A knee-brace system is a structural component that transfers wind pressures exerted on the sidewalls and roof of a farm building to its foundation. This, of course, induces shear and bending in the stud or pole. Knee braces are an effective wind-bracing system for either pole or stud-framed farm buildings.

This plan includes design information and construction details for knee-braced pole and stud frames.

DESIGN INFORMATION

Design wind pressures for locations across Canada and criteria for determining design wind forces for buildings of various shapes are given in the Supplement to the National Building Code of Canada 1990. For low human-occupancy farm buildings, the Canadian Farm Building Code 1990 permits the use of the 1/10 hourly wind pressure, as tabled in the supplement, for design purposes. For each kneebracing system it was assumed that: 1) the knee braces were spaced at 2400mm (8 ft) on center; 2) truss members, knee braces and studs were S-P-F Not or better and 3) the poles were North Species No.1 or better.

SELECTION TABLES

The selection tables below were developed for low human occupancy farm buildings with a roof slope of 1:3. Use Tables 1 and 2 to select a knee-brace system for stud-framed buildings, and Tables 3 and 4 for pole-framed buildings. These tables include the unfactored 1/10 hourly wind pressure that the building can resist for a given stud or pole size. The tables also specify the number of fasteners required in the knee brace-to-stud or pole, truss-to-wall and wall-to-foundation connections.

CONSTRUCTION DETAILS

Figures 1, 2, 3 and 4 give complete construction details for the knee-bracing systems. Figures 1 and 2 give construction details and procedures for kneebraced stud walls up to 4.8 m (16 ft) high. Figure 3

gives the construction details for a knee-braced pole frame where the plate members are notched into the outside of the pole, while Figure 4 gives details for a knee-braced pole frame where the individual members of the two-member plate beam sit on scabs on both sides of the pole. The details in both Figures 3 and 4 can be used for wall heights up to 6 m (20 ft).

It is very important to properly install the connections to ensure an effective wind-bracing system that will provide adequate stiffness and strength to the studs or poles. The knee braces can cause stress reversal in the truss web members. For this reason, all truss web members longer than 1.2 m (4 ft) must be laterally supported at 1200 mm (48 in.) o.c. or less.

Example:

Determine the knee-brace design for a farm building with a gable roof (metal roof, no ceiling) exposed to wind with a 3.6 m (12 ft) wall height, 15 m (50 ft) span, 1:3 (18.4x) roof slope, purlins at 0.6 m (2 ft) o.c., rafters at 1.2 m (4 ft) o.c. for Montreal, Quebec.

1. The design wind load for the building is obtained from the Supplement to the National Building Code of Canada (NBCC) 1990. For Montreal, the 1/10 hourly wind pressure equals 0.31 kPa.
2. Using Table 1, the maximum wind load for a 3.6 m (12 ft) high knee-braced stud wall is 0.36 kPa which is adequate for this building for Montreal. Alternatively, using Tables three and four, the maximum wind load for a 3.6 m (12 ft) high knee-braced pole-framed wall with 140 x 140 mm (6 x 6 in.) poles and 38 x 184 mm (2 x 8 in.) knee braces, is 0.43 kPa which is satisfactory for this situation. The construction details for this knee-brace design are given in Figures 3 and 4, and Tables 3 and 4. It is important that the truss web members and lower chord be laterally braced at 1.2 m (4 ft) on center or less to resist the stress reversals in the roof truss caused by the wind loading.

REFERENCES

Masse, D.I.; Turnbull, J.E.; Seguin, G. and Samson, J.; 1989. Lateral flexibility of knee-braced stud and pole frames. Trans. of the ASAE, 32(3): 1081-1086.

TABLE 1 CONSTRUCTION DETAILS FOR THE KNEE-BRACED^a STUD WALL SHOWN IN FIG. 1.

| Wall height m (ft) | Maximum unfactored wind load kPa | No. of 4.33 x 102mm (4 in.) common spiral nails in connections | | No. of 4 x38mm (1.5 in.) concrete nails in connection |
|-----------------------|---|--|-----|--|
| | | 11 | 12b | |
| 2.4 (8) | 0.64 | 4 | 8 | 6 |
| 3.0 (10) | 0.51 | 4 | 8 | 6 |
| 3-6 (12) | 0.36 | 4 | 8 | 6 |
| 4.2 (14) | 0.25 | 4 | 8 | 6 |
| 4.8 (16) | 0.30 | 4 | 8 | 6 |

^a design based on a knee-brace spacing of 2.4 m (8 ft) o.c.

^b nails clinched

^c indicates no. of nails to truss and stud connections, e.g. 6 refers to 6 nails through joist hangers to truss, and 6 nails through joist hangers to stud

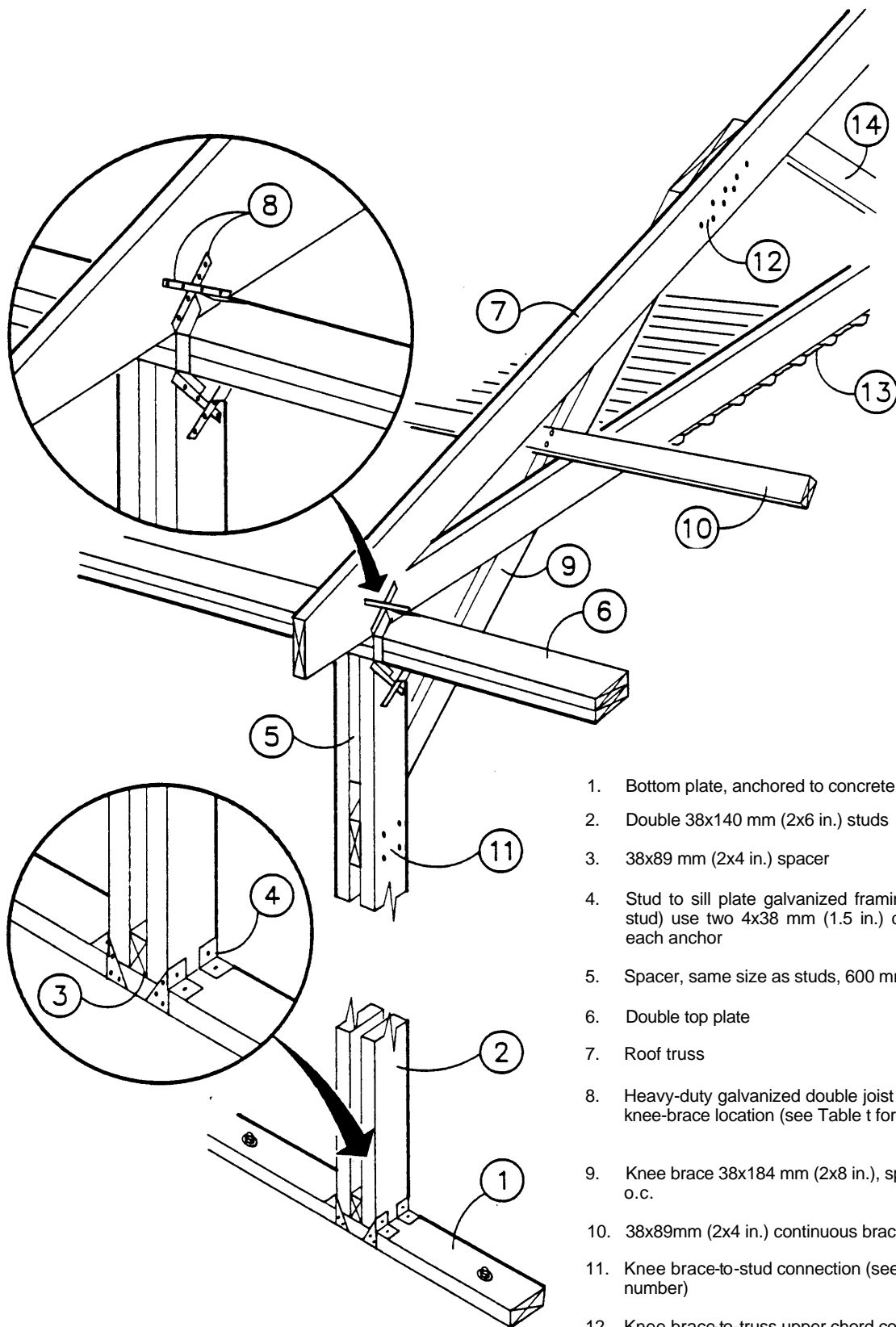

1. Bottom plate, anchored to concrete foundation
2. Double 38x140 mm (2x6 in.) studs
3. 38x89 mm (2x4 in.) spacer
4. Stud to sill plate galvanized framing anchors, (four per double stud) use two 4x38 mm (1.5 in.) concrete nails in each tab of each anchor
5. Spacer, same size as studs, 600 mm (2 ft) long
6. Double top plate
7. Roof truss
8. Heavy-duty galvanized double joist hanger, two required @ each knee-brace location (see Table t for nail size and number)
9. Knee brace 38x184 mm (2x8 in.), spaced @ 2400 mm (8 ft) o.c.
10. 38x89mm (2x4 in.) continuous bracing, nail to 9
11. Knee brace-to-stud connection (see Table t for nail size and number)
12. Knee brace-to-truss upper chord connection (see Table t for nail size and number)
13. Truss lower chord, must be laterally supported by ceiling sheathing or nailing girts at 1200 mm (48 in.) o.c. max.
14. All truss web members longer than 1200 mm (48 in.) must be laterally supported at 1200 mm (48 in.) o.c. or less.

FIGURE 1 LIGHT DUTY KNEE-BRACES FOR STUD WALLS

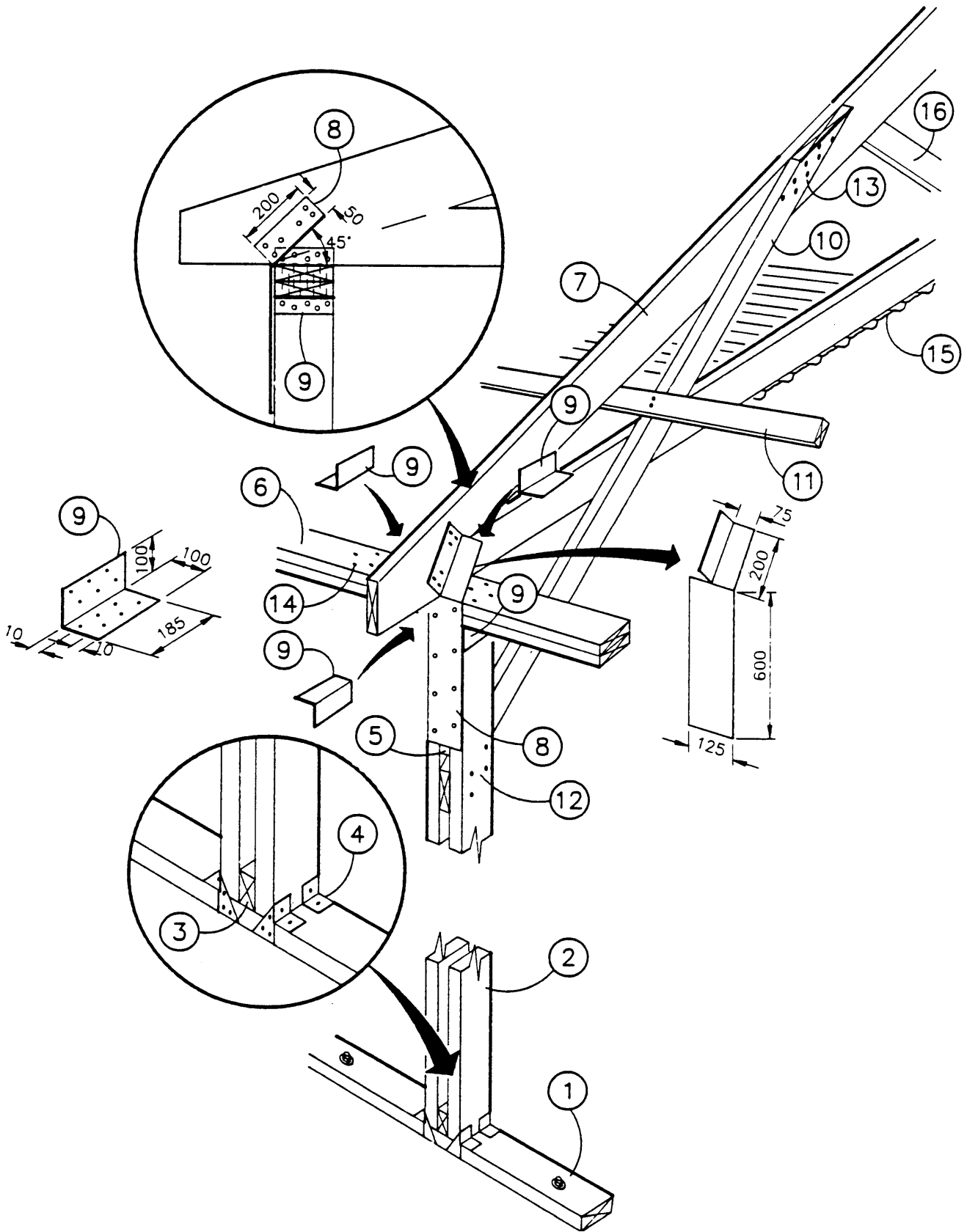

FIGURE 2 HEAVY DUTY KNEE-BRACES FOR STUD WALLS

1. Bottom plate, anchored to concrete foundation
2. Double studs, see Table 2 for size
3. 38x89 mm (2x4 in.) spacer
4. Stud to sill plate galvanized framing anchors, (four per double stud) use two 448 mm (1.5 in.) concrete nails in each tab of each anchor
5. Spacer same size as studs, 600 mm (2 ft) long
6. Double top plate
7. Roof truss
8. 1.52 mm (16 gauge) galvanized steel truss-to-stud anchor, one required @ each knee-brace location, pre-drill for nails, see Table 2 for nailing requirements
9. 1.52 mm (16 gauge) galvanized steel truss-to-plate and plate-to-stud anchors, pre-drill for nails, see Table 2 for nailing requirements
10. Knee brace, spaced @ 2400 mm (8 ft) o.c., see Table 2 for size
11. 38 x 89 mm (2 x 4 in.) continuous bracing, nail to 10
12. Knee brace-to-stud connection, see Table 2 for nailing requirements
13. Knee brace-to-truss connection, see Table 2 for nailing requirements
14. Nail double plate with 4x102 mm (4 in.) spiral nails clinched, four nails each side of truss
15. Truss lower chord, must be laterally supported by ceiling sheathing or nailing girts at 1200 mm (48 in.) o.c. max.
16. All truss web members longer than 1200 mm (48 in.) must be laterally supported at 1200 mm (48 in.) o.c. or less

TABLE 2 CONSTRUCTION DETAILS FOR THE KNEE-BRACED_a STUD WALL SHOWN IN FIG. 2.

| Wail height m (ft) | Stud size mm (in.) | Knee brace sizes | | Maximum unfactored wind load kPa | No. of 4 x 62mm (2.5 in.) concrete nails in connections | | No. of 4.33 x 102mm (4 in.) common spiral nails in connections | |
|-----------------------|-----------------------|-------------------|-------------------|---|--|----|--|-----|
| | | mm (in.) | mm (in.) | | 8b | 9c | 12 | 13d |
| 3.6 (12) | 38 x 184 (2 x 8) | 38 x 184 (2 x 8) | 38 x 184 (2 x 8) | 0.55 | 6 | 3 | 4 | 8 |
| 4.2 (14) | 38 x 184 (2 x 8) | 38 x 184 (2 x 8) | 38 x 184 (2 x 8) | 0.40 | 6 | 3 | 4 | 8 |
| 4.8 (16) | 38 x 235 (2 x 10) | 38 x 235 (2 x 10) | 38 x 235 (2 x 10) | 0.39 | 8 | 4 | 5 | 10 |

a design based on knee braces spaced at 2.4 m (8 ft) o.c.

b indicates no. of nails to truss and pole; e.g. 6 refers to 6 nails through steel anchor to truss and 6 nails through steel anchor to double studs.

c indicates number of nails in each leg of angle

d nails clinched

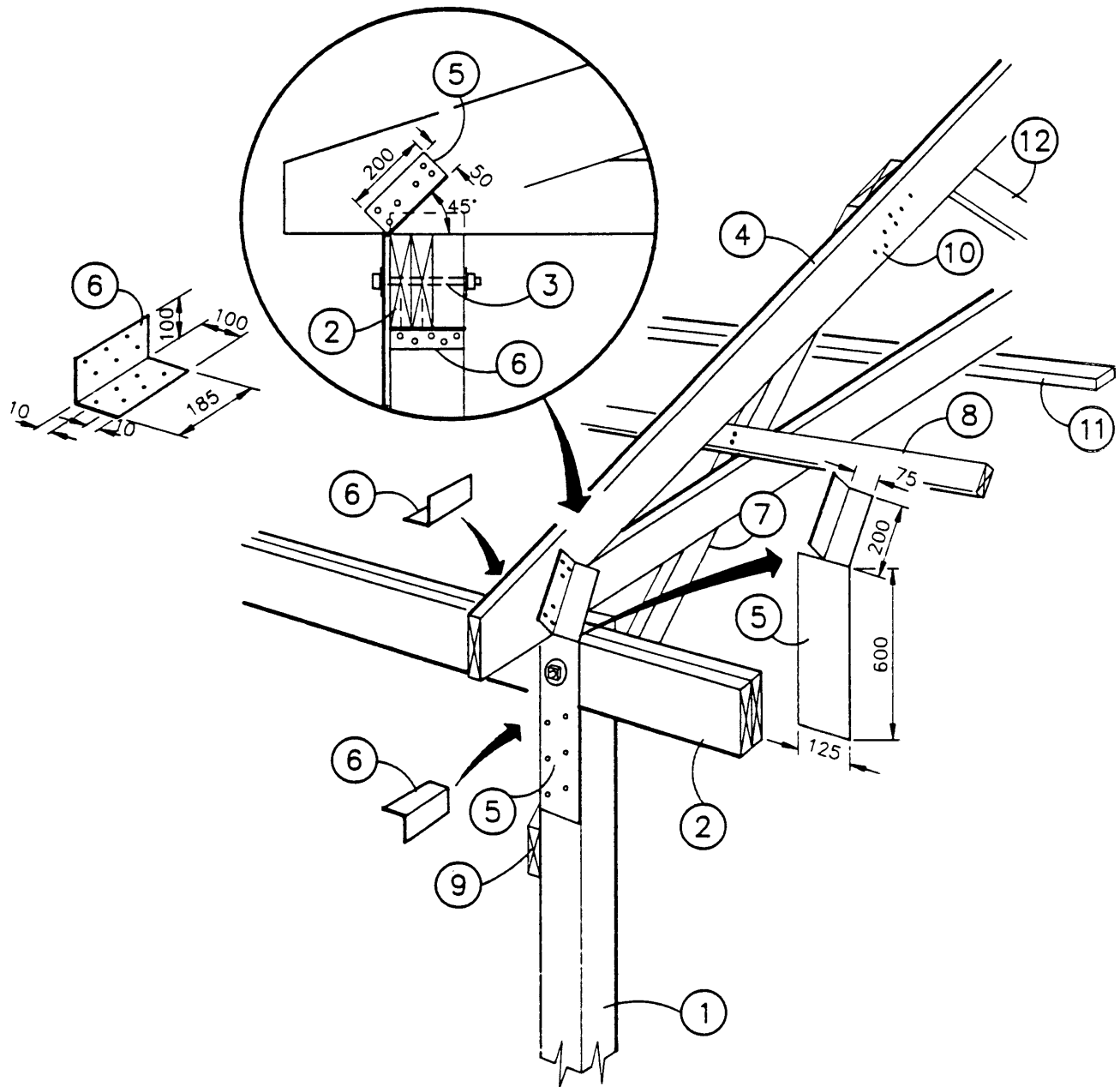

FIGURE 3 POLE FRAMES WITH PLATE MEMBERS NOTCHED INTO POLE

1. Pole, 2.4 m (8 ft) o.c., see table for size
2. Plate beam, notched into pole
3. Bolted connection
4. Roof truss
5. 1.52 mm (16 gauge) galvanized steel truss-to-pole anchor, one required @ each pole, pre-drill for nails, see Table 3 for nailing requirements
6. 1.52 mm (16 gauge) galvanized steel angle (truss-to-platebeam and plate-beam-to-pole anchors), two required @ each pole, pre-drill for nails, see Table 3 for nailing requirements
7. Knee brace 38 x 184 mm (2 x 8 in.), spaced @ 2400 mm (6 ft) o.c. at each pole
8. 38 x 89 mm (2 x 4 in.) continuous bracing, nail to 7
9. Knee brace-to-pole connection, see Table 3 for nailing
10. Knee brace-to-truss connection, see Table 3 for nailing
11. Truss lower chord, must be laterally supported by ceiling sheathing or nailing girls at 1200 mm (48 in.) o.c. max.
12. All truss web members longer than 1200 mm (48 in.) must be laterally supported at 1200 mm (48 in.) o.c. or less

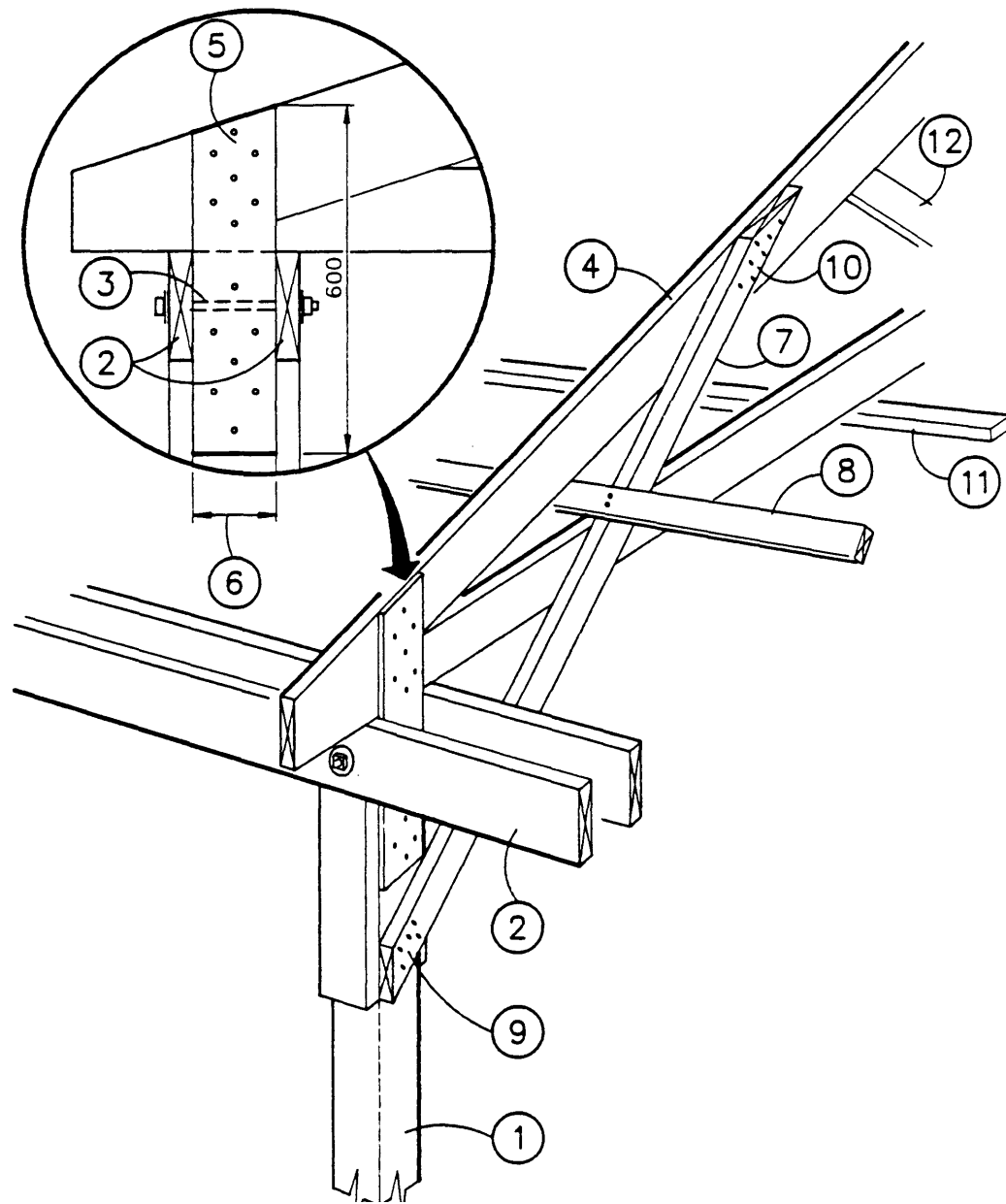

FIGURE 4 POLE FRAMES WITH PLATE MEMBERS ON SCABS

- | | | | |
|----|--|-----|--|
| 1. | Pole, 2.4 m (8 ft) o.c., see table for size | 7. | Knee brace 38 x 184 mm (2 x 8 in.) at each pole |
| 2. | Plate beam | 8. | 38 x 89 mm (2 x 4 in.) continuous bracing, nailed to 7 |
| 3. | Bolted connection | 9. | Knee brace-to-pole connection, see Table 4 for nailing |
| 4. | Roof truss | 10. | Knee brace-to-truss connection, see Table 4 for nailing |
| 6. | 18.5 mm (0.75 in.) Douglas fir plywood truss-to-pole anchor, see Table 4 for nailing | 11. | Truss lower chord, must be laterally supported by ceiling sheathing or nailing girts at 1200 mm (48 in.) o.c. max. |
| 6. | Width equal to pole depth | 12. | All truss web members longer than 1200 mm (48 in.) must be laterally supported at 1200 mm (48 in.) o.c. or less |

TABLE 3 CONSTRUCTION DETAILS FOR THE KNEE-BRACED_a POLE FRAME SHOWN IN FIG. 3

| Wall height m (ft) | Pole sizes mm (in.) | Maximum unfactored wind load kPa | No. of 4 x 38mm (1.5 in.) concrete nails in connections | | No. of 4.33 x 102mm (4 in.) common spiral nails in connection | |
|-----------------------|------------------------|---|--|----------------|---|-----------------|
| | | | 5 ^b | 6 ^c | 9 | 10 ^d |
| 2.4 (8) | 89 x 140 (4 x 6) | 0.58 | 7 | 2 | 4 | 4 |
| 3.0 (10) | 89 x 140 (4 x 6) | 0.40 | 6 | 2 | 4 | 4 |
| | 140 x 140 (6 x 6) | 0.58 | 8 | 3 | 4 | 4 |
| 3.6 (12) | 89 x 140 (4 x 6) | 0.29 | 4 | 2 | 4 | 4 |
| | 140 x 140 (6 x 6) | 0.43 | 6 | 3 | 4 | 4 |
| | 140x184 (6x8) | 0.71 | 9 | 4 | 6 | 6 |
| 4.2 (14) | 140 x 140 (6 x 6) | 0.32 | 5 | 3 | 4 | 4 |
| | 140 x 140 (6 x 8) | 0.54 | 8 | 4 | 6 | 6 |
| | 184x184 (8x8) | 0.70 | 9 | 5 | 8 | 8 |
| 4.8 (16) | 140 x 140 (6 x 6) | 0.24 | 4 | 3 | 4 | 4 |
| | 140x184 (6x8) | 0.41 | 6 | 4 | 6 | 6 |
| | 184 x 184 (8 x 8) | 0.54 | 8 | 5 | 8 | 8 |
| 6.0 (20) | 140 x 184 (6 x 8) | 0.26 | 5 | 4 | 6 | 6 |
| | 184x184 (8x8) | 0.35 | 6 | 5 | 8 | 8 |

a design based on poles and knee braces spaced at 2.4 m (8) o.c

b indicates no. of nails to truss and pole; e.g. 7 refers to 7 nails through steel anchor to truss, and 7 nails through steel anchor to pole.

c indicates number of nails in each leg of angle

d nails clinched

TABLE 4 CONSTRUCTION DETAILS FOR THE KNEE-BRACED_a POLE FRAME SHOWN IN FIG. 4

| Wall height m (ft) | Pole size mm (in.) | Maximum unfactored wind load kPa | No. of 4.33 x 102mm (4 in.) common spiral nails in connections | | |
|-----------------------|-----------------------|---|---|-----------------|----------------|
| | | | 9 | 10 ^b | 5 ^c |
| 2.4 (8) | 89 x 140 (4 x 6) | 0.58 | 4 | 4 | 5 |
| 3.0 (10) | 89 x 140 (4 x 6) | 0.40 | 4 | 4 | 5 |
| | 140 x 140 (6 x 6) | 0.58 | 4 | 4 | 6 |
| 3.6 (12) | 89 x 140 (4 x 6) | 0.29 | 4 | 4 | 4 |
| | 140x140 (6x6) | 0.43 | 4 | 4 | 4 |
| | 140x184 (6x8) | 0.71 | 6 | 6 | 8 |
| 4.2 (14) | 140 x 140 (6 x 6) | 0.32 | 4 | 4 | 8 |
| | 140x184 (6x8) | 0.54 | 6 | 6 | 8 |
| | 184x184 (8x8) | 0.70 | 8 | 8 | 10 |
| 4.8 (16) | 140 x 140 (6 x 6) | 0.24 | 4 | 4 | 8 |
| | 140x184 (6x8) | 0.41 | 6 | 6 | 8 |
| | 184 x 184 (8 x 8) | 0.54 | 8 | 8 | 10 |
| 6.3 (20) | 140 x 184 (6 x 8) | 0.26 | 6 | 6 | 8 |
| | 184 x 184 (8 x 8) | 0.35 | 8 | 8 | 10 |

a design based on poles and knee braces spaced at 2.4 m (8) o.c.

b nails clinched

c indicates no. of nails to truss and pole; e.g. 5 refers to 5 nails through plywood to truss, and 5 nails through plywood to pole.