

SLIDING DOORS

COMPLETE INSTRUCTIONS

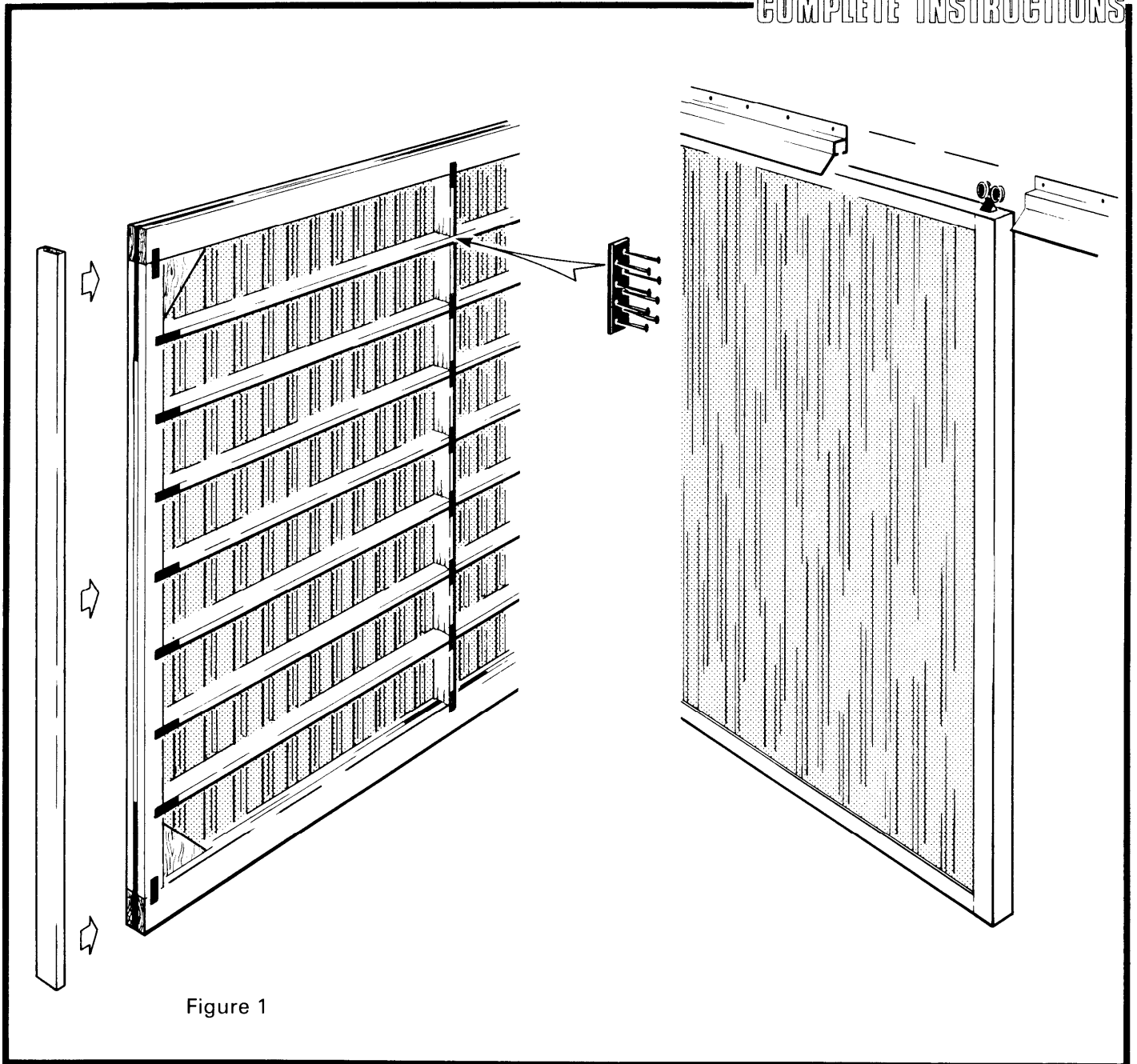

Figure 1

SLIDING DOORS

PLAN M-9341 REV 85-11

Poorly-made sliding doors may blow in during severe windstorms. If this happens, the full pressure of the wind fills the inside of the building, and if no other openings happen to blow open to release this pressure, the entire building may blow apart.

This plan gives a method of framing stronger sliding doors, to resist windstorms as well as the abuse of frequent opening and closing. Table 1 gives the allowable wind pressures for 2 x 4 horizontal framing, placed on edge to make a stronger, stiffer door.

For example, a door 4800 mm (16 ft) wide for a barn at Moose Jaw, Sask., should be designed for a 1/10 hourly wind pressure of 0.36 kPa, according to the *Supplement, National Building Code of Canada 1985*. Table 1 shows that 4800 mm (16 ft) door girts spaced 600 mm (2 ft) on center are safe up to 0.39 kPa, which is good for Moose Jaw.

In addition to framing the door with girts on edge, a special corner detail is used: a triangular plywood gusset is sandwiched between doubled framing at sides, top and bottom. This stiffens the corners and provides for a uniform frame thickness of 89 mm (3½ in.). Be sure that the roller-hanger hardware can be adjusted to this thickness. For doors 3600 mm (12 ft) and wider, three hanger sets are recommended.

Sliding doors made this way can be covered on the outside with vertical corrugated steel, exterior plywood or other exterior siding materials. With steel siding, detail 13, Figure 2 shows two methods of trimming and flashing the outside edges of the door. The method with the covered face board 11 is a little more 'deluxe'. If you need an insulated door, add glass fiber friction-fit insulation between the girts (space them at 400 or 600 mm to match the insulation), cover the inside face with polyethylene vapor barrier and exterior-sheathing plywood. If the door is fully sheathed on the inside, omit the sheet steel nailing straps, Figure 2, 9, and Figure 1.

FRAMING AROUND SLIDING DOORS

Sliding doors can be put in end or side walls. The end location is preferred because the roof trusses overhead eliminate the need for a heavy head beam to carry roof loads, and because there are fewer problems with snow and rain from the roof above the doorways. Nevertheless there are situations where a sidewall doorway is necessary, so both locations are detailed here.

Figure 3 gives suggested framing details for endwall doorways in a stud-wall building. Here the main problem is to hang the door track so that the first gable end truss carries the door weight, and the second truss is tied in to prevent twist and sway at the door header. This is done with X-bracing 14 spiked between the first and second trusses. For doorways up to 6 m (20 ft) wide, three X-braces are recommended, one at midspan and one at each end of the doorway. This same X-bracing also serves to keep the trusses from toppling over during that critical stage of construction before the roofing goes on. This X-bracing may be installed vertically, or it may be easier to angle the bracing in plane with the truss compression struts. Plan M-9102, Truss Erecting and Bracing, gives more details on this.

Figure 4 gives details for the sidewall location. Here the roof load (usually trusses) must be supported above the doorway. The head beam may be a laminated wood beam 4 for smaller buildings and smaller doorways. For wider doorways and wider truss spans the load limits for wood beams often are too low and a steel beam 5 must be used. For wood and steel head beam requirements, see plan M-9313.

For pole frame construction, some of the detailing about the door track and head beam is slightly modified. Figure 5 gives pole frame details in gable endwalls, and Figure 6 gives pole frame details at sidewalls. In these details all poles are the same height in both end and side walls. Some builders prefer to use longer poles at the endwalls, extending them to connect with the truss top chords. This is more expensive and is not essential as long as the gable end X-bracing 13 is carefully installed as shown in Figure 5.

TABLE 1 DESIGN OF 2 x 4 GIRTS ON EDGE BASED ON GRADE NO. 2, S-P-F

Nominal door width		Maximum 1/10 hourly wind pressure, kPa for girts spaced @			
		400 m m (16 in.)	600 m m (24 in.)	800 m m (32 in.)	1 200 m m (48 in.)
mm	(ft)				
2 400	(8)	-	-	1.24	0.83
3 000	(10)	-	1.06	0.79	0.53
3 600	(12)	-	0.74	0.56	0.36
4 200	(14)	0.82	0.55	0.41	0.27
4 800	(16)	0.62	0.42	0.31	-

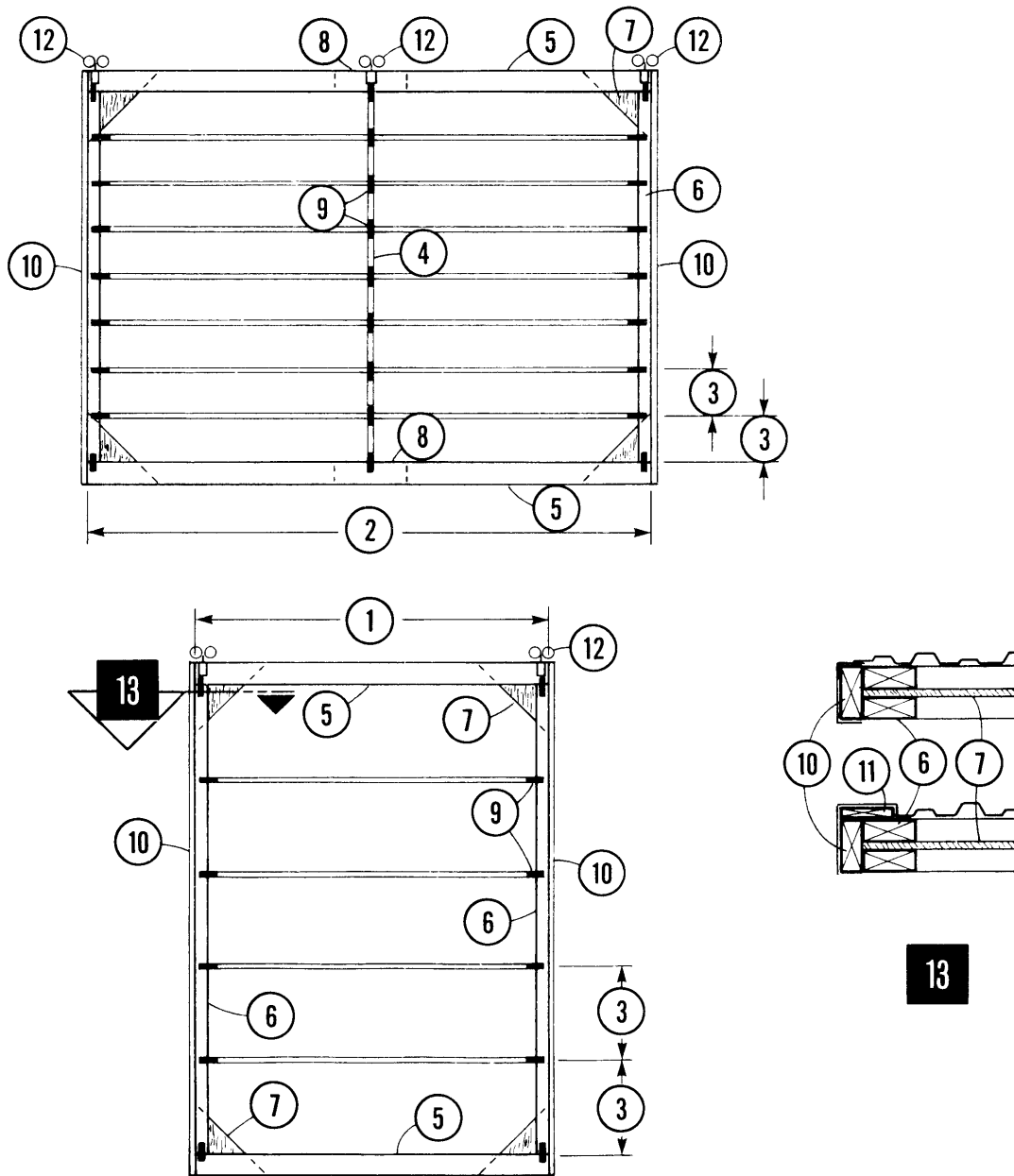

- | | |
|--|--|
| <ul style="list-style-type: none"> 1 nominal door width up to 3000 mm (10 ft) 2 nominal door width from 3300 to 4800 mm (11 to 16 ft) 3 2 x 4 girt spacing, adjust for door width and wind load 4 2 x 4 blocking, fit between girts 5 2-2 x 8 6 2-2 x 4 7 12.5 mm (½ in.) plywood gussets at four corners | <ul style="list-style-type: none"> 8 12.5 mm (½ in.) plywood spacers 9 galvanized steel strap nailed to frames with 38 mm (1½ in.) large-head roofing nails 10 2 x 4 side cap 11 1 x 4 face board, optional 12 hanger and roller hardware, three sets for doors 3600 mm (12 ft) wide and wider 13 section across top door corner |
|--|--|

Figure 2

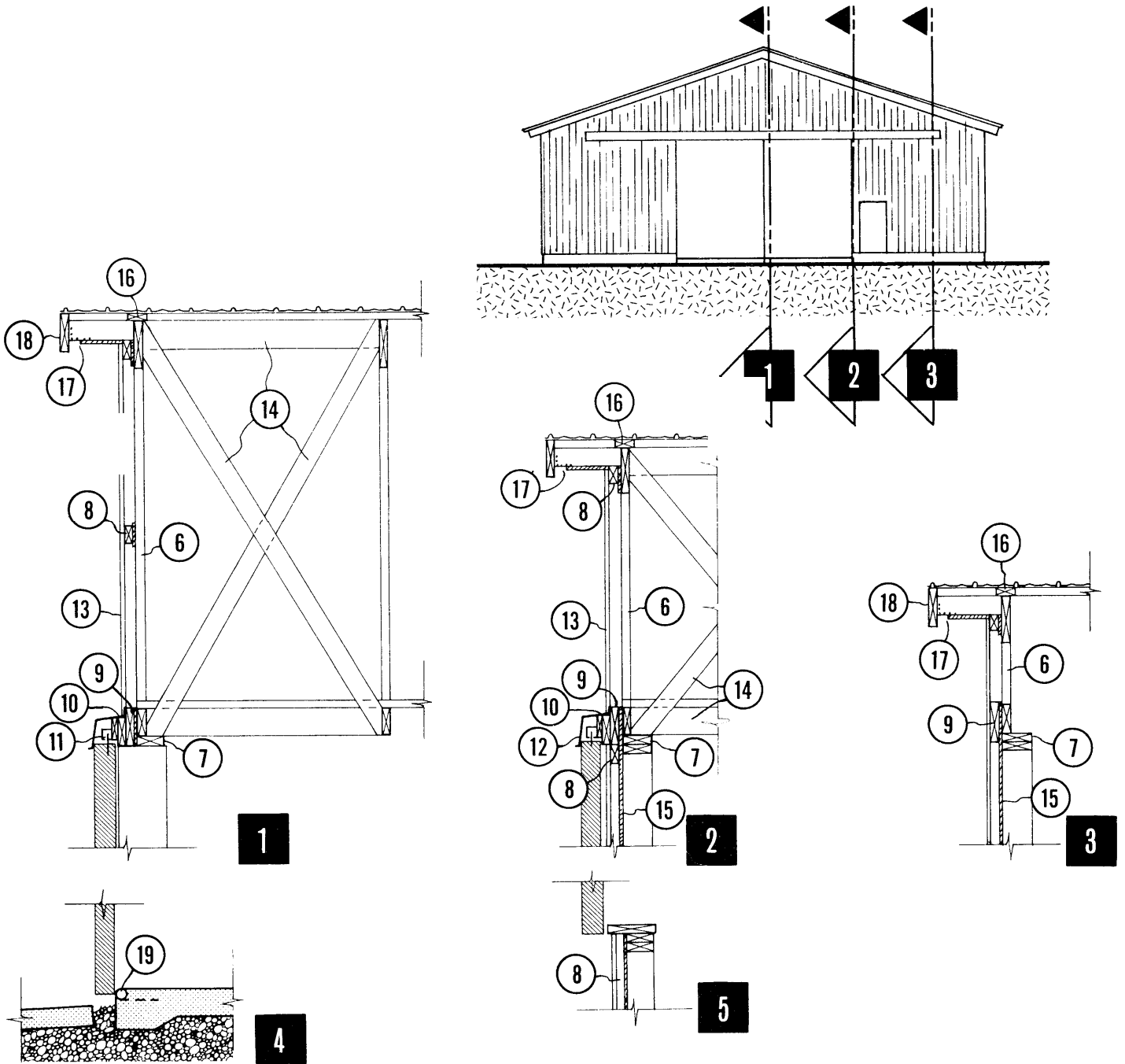

- | | |
|---|---|
| <ul style="list-style-type: none"> 1 section at center of doorway 2 section beside doorway 3 section beyond ends of door track 4 section at door threshold 5 section at door side jambs 6 roof truss at gables 7 top wall plate, same width as studs 8 2 x 4 siding girts, spaced as per siding manufacturer, vertical stee siding, waferboard spacers as 15 9 2 x 8 head plank, blocking for siding 10 2 x 6 track board and 25 mm filler 11 door track hangers lag-screwed to 10 and 9, spaced out to center of door thickness | <ul style="list-style-type: none"> 12 galv. steel door flashing 13 galv. siding over 12 14 2 x 6 blocking and 2 x 4 X-bracing between first and second trusses 15 extra endwall cladding may be required for diaphragm wind bracing (see Plan M-8313) 16 optional blocking for diaphragm wind bracing 17 50 mm screened vent slot 18 2 x 8 face board, prepainted steel cover optional 19 reinforce edge of floor slab with 1 ¼ in. galv. pipe |
|---|---|

Figure 3 Details for sliding doors in gable endwalls, stud wall construction

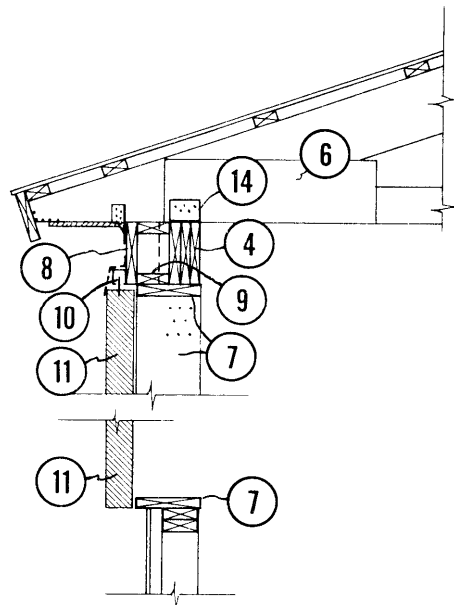

1

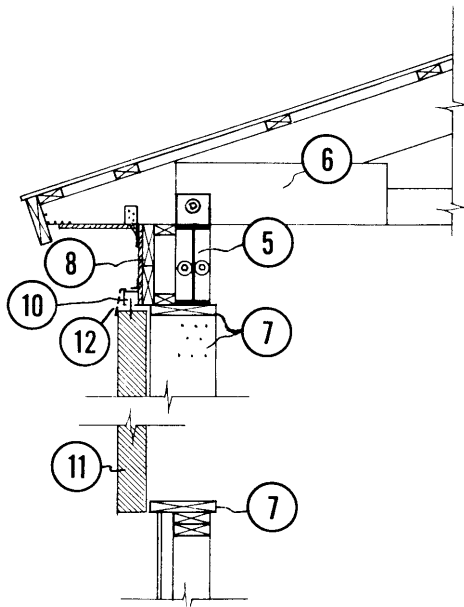
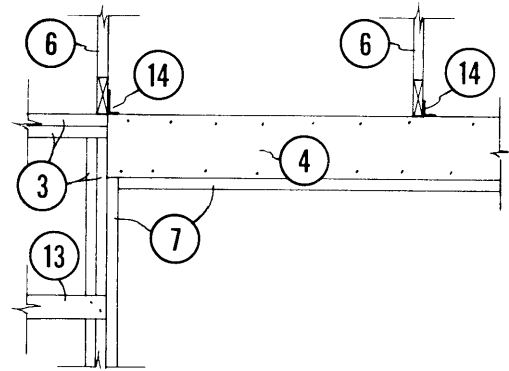

2

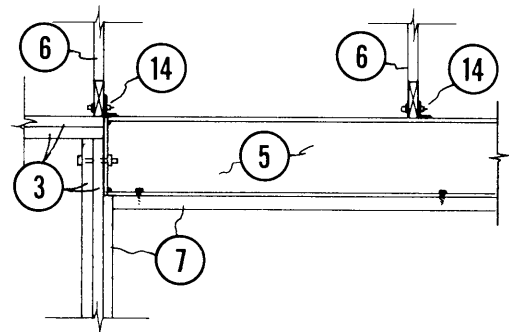

- 1 laminated plank lintel, sections and elevation
- 2 steel beam lintel, sections and elevation
- 3 double 2 x 6 side jamb studs and top plate
- 4 three-member laminated plank lintel (may add 4th and 5th plank if required)
- 5 steel I-beam lintel; end plates welded to I-beam, two ½ in. bolts to studs
- 6 roof truss
- 7 2 x 10 head and side jambs; side jamb butts tight under 4 or 5

- 8 track board, same depth as lintel (do not count as part of the lintel)
- 9 spacer blocking, ripped to width, locates door track 10 above center of door thickness
- 10 door track, hangers and lag screw to 8
- 11 sliding door, see Figures 1 and 2
- 12 galvanized steel flashing over track and door, optional
- 13 2 x 4 wall purlins, vertical steel siding
- 14 truss anchor clips

Figure 4 Details for sliding doors in sidewalls, stud wall construction

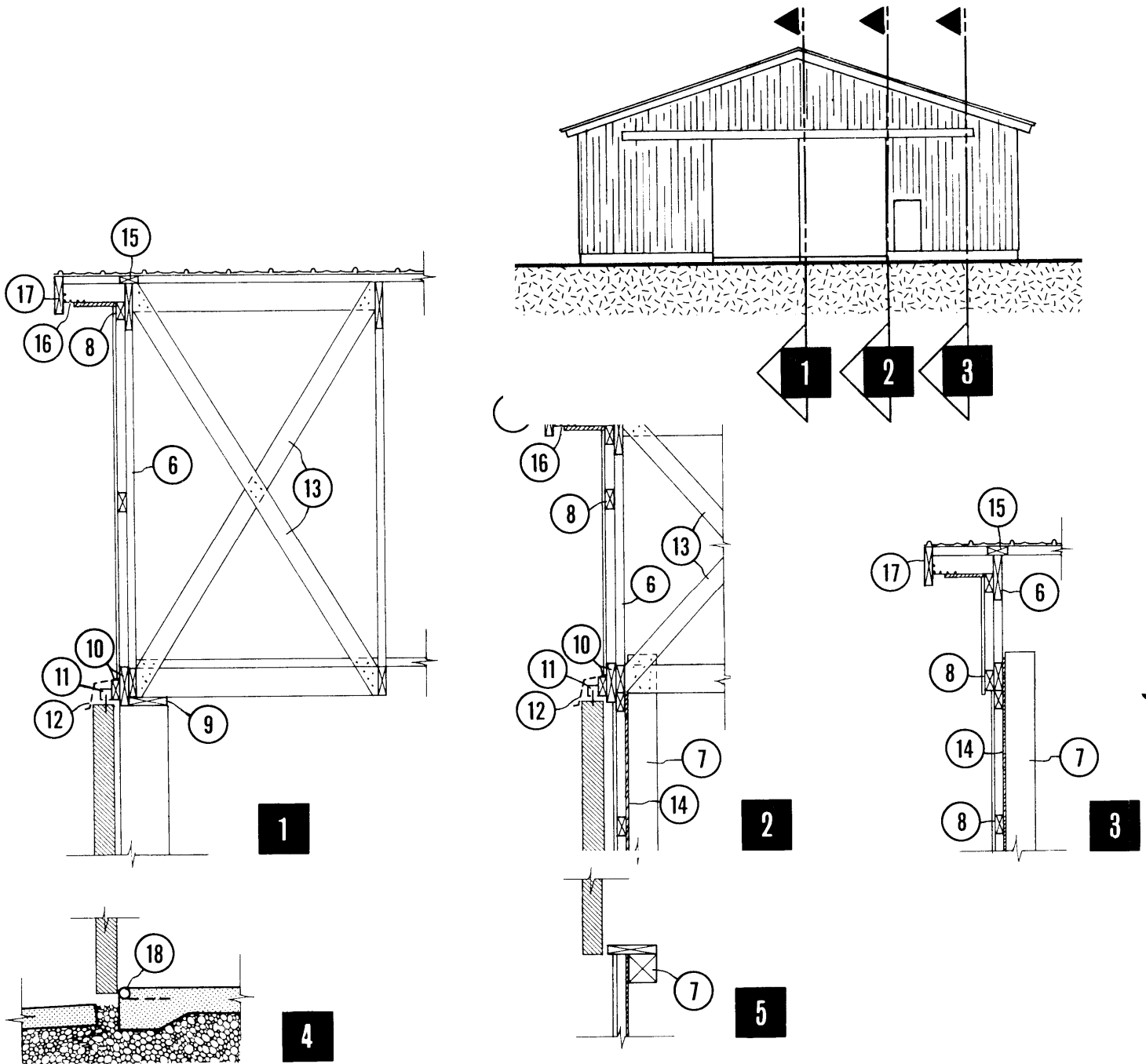

- | | |
|--|--|
| [1] section at center of doorway | 11 door track hangers lag-screwed to 10 |
| [2] section just beyond doorway | 12 galvanized steel track flashing |
| [3] section beyond ends of door track | 13 2 x 6 blocking and 2 x 4 X-bracing |
| [4] section at door threshold | between first and second trusses, at |
| [5] section at door side jambs | two sides and center of doorway |
| 6 roof truss at gables | 14 extra endwall cladding may be |
| 7 pressure-treated sawn wood poles at | required for diaphragm wind bracing |
| 8 2 x 4 siding girts, spaced as per siding | 15 optional blocking for diaphragm wind |
| manufacturer, vertical steel siding | bracing |
| 9 2 x 8 door head jamb | 16 50 mm (2 in.) screened vent slot |
| 10 2 x 8 head plank and 2 x 6 track board | 17 2 x 8 face board, prepainted steel |
| places door track above center of door | flashing optional |
| thickness | 18 reinforce edge of floor slab with 1 ¼ |
| | in. galvanized pipe welded to 15 M |
| | rebar lags at 900 mm oc |

Figure 5 Details for sliding doors in gable endwalls, pole frame construction

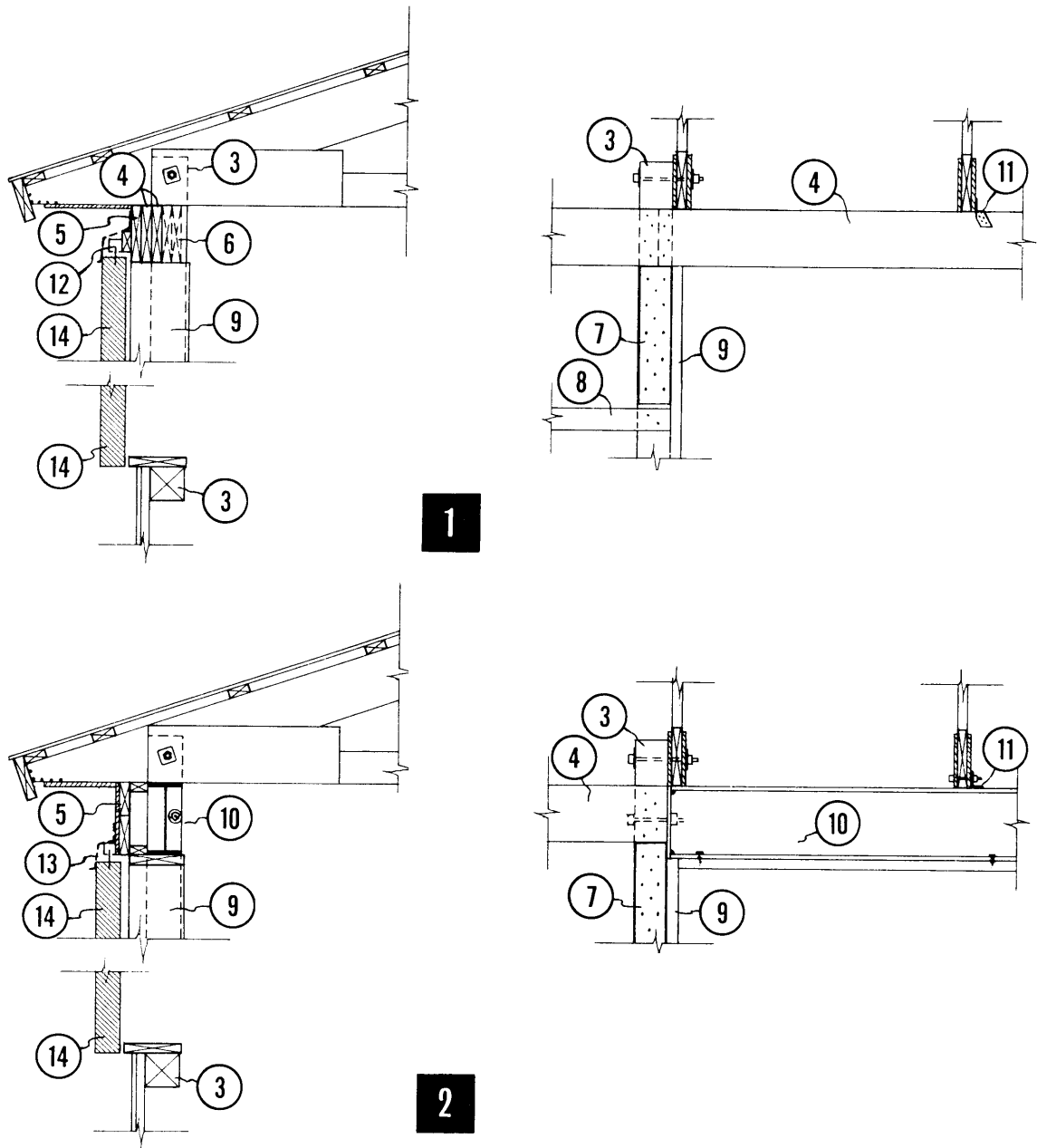

- [1] laminated plank lintel, sections and elevation
- [2] steel beam lintel, sections and elevation
- 3 pressure-treated sawn wood poles both sides of doorway and at 2400 mm (8 ft) spacing beyond doorway
- 4 double plate beam, one notched into poles, joints staggered 2400 mm (8 ft) at poles
- 5 track board same depth as 4 or 10
- 6 additional head beam to handle increased roof load due to lintel spans exceeding 2400 mm (8ft)
- 7 2 x 6 blocking nailed to pole to support outer member of 4

- 8 2 x 4 siding girts, spaced as per manufacturer, vertical steel siding
- 9 2 x 8 or 2 x 10 side jamb, butts tight under steel or wood lintel
- 10 steel I-beam lintel, end plate welded to I-beam and bolted to pole 3
- 11 L-clip steel truss anchors welded to 10, nailed to trusses and plate beam 4
- 12 door track, hangers and lag bolts to track board M6
- 13 galvanized steel flashing over track 12 and door 14, optional
- 14 sliding door

Figure 6 Details for sliding doors in sidewalls, pole frame construction

DOORS ON INCLINED TRACKS

Sliding doors are usually made to roll on horizontal track. This way the door can be left standing in any position (open, closed or partly open). A different idea is to run the door on inclined track; this has the advantage that when opened, the door lifts off the threshold and is immediately free of ice and other obstructions along the bottom (see Figure 7). A counterweight 1 is connected to the door with a cable-and-pulley system, to balance the effect of the inclined track. With the two pulleys, the counterweight moves vertically one-half the distance the door moves along the track. This two-pulley arrangement is essential if the door is wider than its height, otherwise the counterweight will meet the ground before the door is fully open. Make the counterweight from a length of steel pipe and weld on a bottom plug and a lifting bail of round steel rod. Fill the pipe with concrete until the door rolls open or closed with equal effort. Use large-diameter, heavy duty cable pulleys with galvanized steel cable and cable clamps. The counterweight may hang either outside or inside the wall, but a box is needed to guide the counterweight, to prevent jamming and to protect livestock and people in case the cable breaks.

The track slope does not necessarily have to be the same as the roof slope as Figure 7 shows, but the steeper the track, the heavier the counterweight 1 must be to balance the door. For example, a door 4.2 x 4.5 m (14 x 15 ft) weighs about 280 kg; with a track slope of 14° (rising 3 on 12), the counterweight

should weigh 195 kg to just balance the door. This is equivalent to a 1.5 m length of 8-inch steel pipe filled with concrete. If this is too big, use iron scrap in the concrete to increase its density.

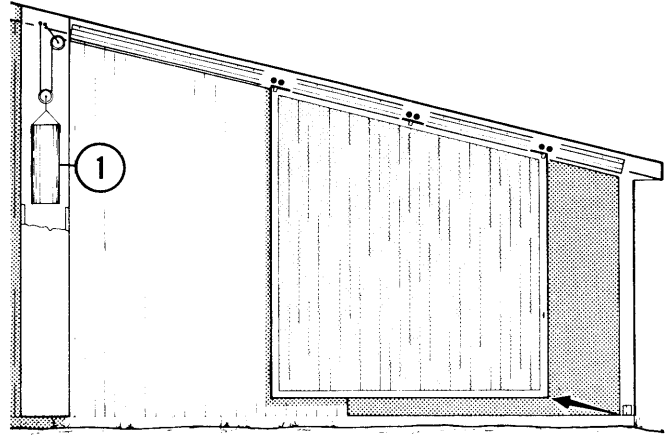

Figure 7 Door on inclined track. The counterweight 1 travels half the distance travelled by the door